

**Impro**  
Fluidtek

Technical Information

# Orbital Motors Type WH





**TABLE OF CONTENTS**

**TECHNICAL INFORMATION**

Operating Recommendations.....	4-5
Motor Connections .....	5
Product Testing (Understanding the Performance Charts).....	6
Allowable Bearing & Shaft Loads .....	7
Vehicle Drive Calculations .....	8-9
Induced Side Loading.....	10
Hydraulic Equations .....	10
Shaft Nut Dimensions & Torque Specifications .....	11

**OPTIONAL MOTOR FEATURES**

Speed Sensor Options.....	12-13
Freeturning Rotor Option .....	13
Internal Drain .....	14
Hydraulic Declutch.....	14
Valve Cavity Option .....	15
Slinger Seal Option.....	15

**MEDIUM DUTY HYDRAULIC MOTORS**

WH Product Line Introduction .....	16
WH Displacement Performance Charts .....	17-20
600 Series Housings .....	21
600 Series Technical Information.....	22
600 Series Portings .....	23-24
600 Series Shafts .....	25
600 Series Ordering Information .....	26
620 Series Housings .....	27
620 Series Technical Information.....	27
620 Series Portings .....	28-29
620 Series Shafts .....	30
620 Series Ordering Information .....	31
630 Series Housings .....	32
630 Series Technical Information.....	32
630 Series Portings .....	33-34
630 Series Shafts .....	35
630 Series Ordering Information .....	36

## OPERATING RECOMMENDATIONS

### OIL TYPE

Hydraulic oils with anti-wear, anti-foam and demulsifiers are recommended for systems incorporating Impro Fluidtek motors. Straight oils can be used but may require VI (viscosity index) improvers depending on the operating temperature range of the system. Other water based and environmentally friendly oils may be used, but service life of the motor and other components in the system may be significantly shortened. Before using any type of fluid, consult the fluid requirements for all components in the system for compatibility. Testing under actual operating conditions is the only way to determine if acceptable service life will be achieved.

### FLUID VISCOSITY & FILTRATION

Fluids with a viscosity between 20 - 43 cSt [100 - 200 S.U.S.] at operating temperature is recommended. Fluid temperature should also be maintained below 85°C [180° F]. It is also suggested that the type of pump and its operating specifications be taken into account when choosing a fluid for the system. Fluids with high viscosity can cause cavitation at the inlet side of the pump. Systems that operate over a wide range of temperatures may require viscosity improvers to provide acceptable fluid performance.

Impro Fluidtek recommends maintaining an oil cleanliness level of ISO 17-14 or better.

### INSTALLATION & START-UP

When installing an Impro Fluidtek motor it is important that the mounting flange of the motor makes full contact with the mounting surface of the application. Mounting hardware of the appropriate grade and size must be used. Hubs, pulleys, sprockets and couplings must be properly aligned to avoid inducing excessive thrust or radial loads. Although the output device must fit the shaft snug, a hammer should never be used to install any type of output device onto the shaft. The port plugs should only be removed from the motor when the system connections are ready to be made. To avoid contamination, remove all matter from around the ports of the motor and the threads of the fittings. Once all system connections are made, it is recommended that the motor be run-in for 15-30 minutes at no load and half speed to remove air from the hydraulic system.

### MOTOR PROTECTION

Over-pressurization of a motor is one of the primary causes of motor failure. To prevent these situations, it is necessary to provide adequate relief protection for a motor based on the pressure ratings for that particular model. For systems that may experience overrunning conditions, special precautions must be taken. In an overrunning condition, the motor functions as a pump and attempts to convert kinetic energy into hydraulic energy. Unless the system is properly

configured for this condition, damage to the motor or system can occur. To protect against this condition a counterbalance valve or relief cartridge must be incorporated into the circuit to reduce the risk of over-pressurization. If a relief cartridge is used, it must be installed upline of the motor, if not in the motor, to relieve the pressure created by the over-running motor. To provide proper motor protection for an over-running load application, the pressure setting of the pressure relief valve must not exceed the intermittent rating of the motor.

### HYDRAULIC MOTOR SAFETY PRECAUTION

A hydraulic motor must not be used to hold a suspended load. Due to the necessary internal tolerances, all hydraulic motors will experience some degree of creep when a load induced torque is applied to a motor at rest. All applications that require a load to be held must use some form of mechanical brake designed for that purpose.

### MOTOR/BRAKE PRECAUTION

**Caution!** - Impro Fluidtek motor/brakes are intended to operate as static or parking brakes. System circuitry must be designed to bring the load to a stop before applying the brake.

**Caution!** - Because it is possible for some large displacement motors to overpower the brake, it is critical that the maximum system pressure be limited for these applications. Failure to do so could cause serious injury or death. When choosing a motor/brake for an application, consult the performance chart for the series and displacement chosen for the application to verify that the maximum operating pressure of the system will not allow the motor to produce more torque than the maximum rating of the brake. Also, it is vital that the system relief be set low enough to insure that the motor is not able to overpower the brake.

To ensure proper operation of the brake, a separate case drain back to tank must be used. Use of the internal drain option is not recommended due to the possibility of return line pressure spikes. A simple schematic of a system utilizing a motor/brake is shown on page 5. Although maximum brake release pressure may be used for an application, a 34 bar [500 psi] pressure reducing valve is recommended to promote maximum life for the brake release piston seals. However, if a pressure reducing valve is used in a system which has case drain back pressure, the pressure reducing valve should be set to 34 bar [500 psi] over the expected case pressure to ensure full brake release. To achieve proper brake release operation, it is necessary to bleed out any trapped air and fill brake release cavity and hoses before all connections are tightened. To facilitate this operation, all motor/brakes feature two release ports. One or both of these ports may be used to release the brake in the

**OPERATING RECOMMENDATIONS & MOTOR CONNECTIONS**

**MOTOR/BRAKE PRECAUTION**

unit. Motor/brakes should be configured so that the release ports are near the top of the unit in the installed position.

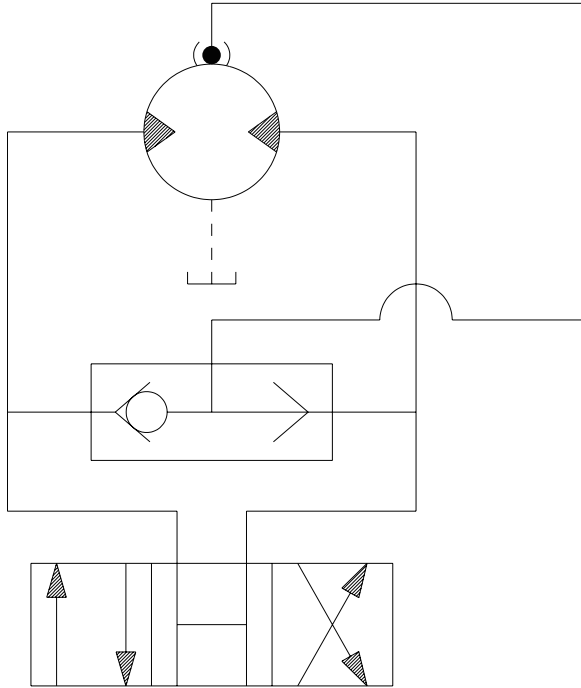

Once all system connections are made, one release port must be opened to atmosphere and the brake release line carefully charged with fluid until all air is removed from the line and motor/brake release cavity. When this has been accomplished the port plug or secondary release line must be reinstalled. In the event of a pump or battery failure, an external pressure source may be connected to the brake release port to release the brake, allowing the machine to be moved.

► NOTE: It is vital that all operating recommendations be followed. Failure to do so could result in injury or death.

**MOTOR CIRCUITS**

There are two common types of circuits used for connecting multiple numbers of motors – series connection and parallel connection.

**SERIES CONNECTION**

When motors are connected in series, the outlet of one motor is connected to the inlet of the next motor. This allows the full pump flow to go through each motor and provide maximum speed. Pressure and torque are distributed between the motors based on the load each motor is to. The maximum system pressure must be no greater than the maximum inlet pressure of the first motor. The allowable back pressure rating for a motor must also be considered. In some series circuits the motors must have an external case drain connected. A series connection is desirable when it is important for all the motors to run the same speed such as on a long line conveyor.

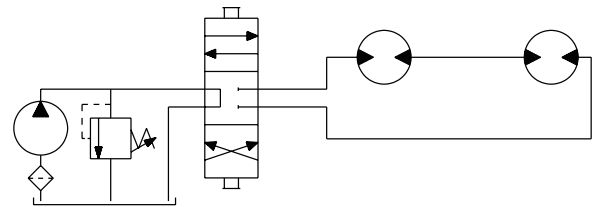

SERIES CIRCUIT

**PARALLEL CONNECTION**

In a parallel connection all of the motor inlets are connected. This makes the maximum system pressure available to each motor allowing each motor to produce full torque at that pressure. The pump flow is split between the individual motors according to their loads and displacements. If one motor has no load, the oil will take the path of least resistance and all the flow will go to that one motor. The others will not turn. If this condition can occur, a flow divider is recommended to distribute the oil and act as a differential.

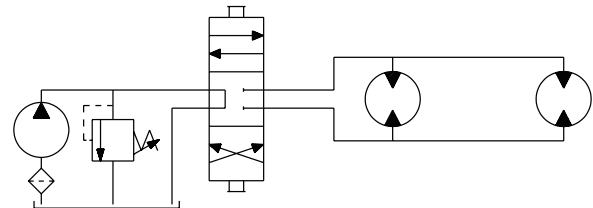

PARALLEL CIRCUIT

► NOTE: The motor circuits shown above are for illustration purposes only. Components and circuitry for actual applications may vary greatly and should be chosen based on the application.

## PRODUCT TESTING

Performance testing is the critical measure of a motor's ability to convert flow and pressure into speed and torque. All product testing is conducted using an Impro Fluidtek state of the art test facility. This facility utilizes fully automated test equipment and custom designed software to provide accurate, reliable test data. Test routines are standardized, including test stand calibration and stabilization of fluid temperature and viscosity, to provide consistent data. The example below provides an explanation of the values pertaining to each heading on the performance chart.

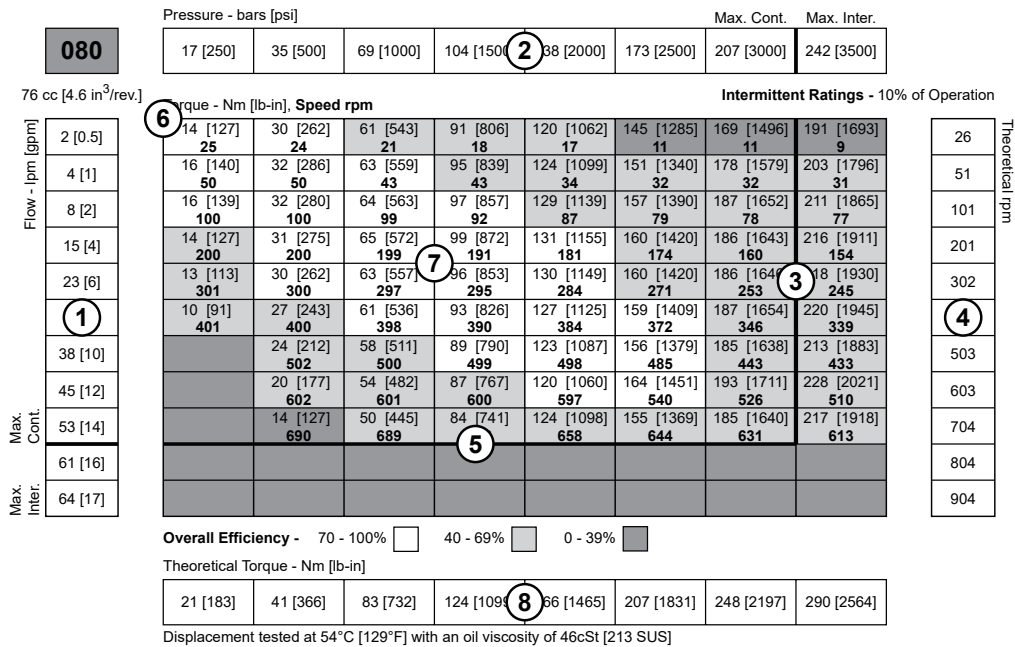

- Flow represents the amount of fluid passing through the motor during each minute of the test.
- Pressure refers to the measured pressure differential between the inlet and return ports of the motor during the test.
- The maximum continuous pressure rating and maximum intermittent pressure rating of the motor are separated by the dark lines on the chart.
- Theoretical RPM represents the RPM that the motor would produce if it were 100% volumetrically efficient. Measured RPM divided by the theoretical RPM give the actual volumetric efficiency of the motor.
- The maximum continuous flow rating and maximum intermittent flow rating of the motor are separated by the dark line on the chart.
- Performance numbers represent the actual torque and speed generated by the motor based on the corresponding input pressure and flow. The numbers on the top row indicate torque as measured in Nm [lb-in], while the bottom number represents the speed of the output shaft.
- Areas within the white shading represent maximum motor efficiencies.
- Theoretical Torque represents the torque that the motor would produce if it were 100% mechanically efficient. Actual torque divided by the theoretical torque gives the actual mechanical efficiency of the motor.

**ALLOWABLE BEARING & SHAFT LOADING**

This catalog provides curves showing allowable radial loads at points along the longitudinal axis of the motor. They are dimensioned from the mounting flange. Two capacity curves for the shaft and bearings are shown. A vertical line through the centerline of the load drawn to intersect the x-axis intersects the curves at the load capacity of the shaft and of the bearing.

In the example below the maximum radial load bearing rating is between the internal roller bearings illustrated with a solid line. The allowable shaft rating is shown with a dotted line.

The bearing curves for each model are based on laboratory analysis and testing results constructed at Impro Fluidtek. The shaft loading is based on a 3:1 safety factor and 330 Kpsi tensile strength. The allowable load is the lower of the curves at a given point. For instance, one inch in front of the mounting flange the bearing capacity is lower than the shaft capacity. In this case, the bearing is the limiting load. The motor user needs to determine which series of motor to use based on their application knowledge.

**ISO 281 RATINGS VS. MANUFACTURERS RATINGS**

Published bearing curves can come from more than one type of analysis. The ISO 281 bearing rating is an international standard for the dynamic load rating of roller bearings. The rating is for a set load at a speed of 33 1/3 RPM for 500 hours (1 million revolutions). The standard was established to allow consistent comparisons of similar bearings between manufacturers. The ISO 281 bearing ratings are based solely on the physical characteristics of the bearings, removing any manufacturers specific safety factors or empirical data that influences the ratings.

Manufacturers' ratings are adjusted by diverse and systematic laboratory investigations, checked constantly with feedback from practical experience. Factors taken into account that affect bearing life are material, lubrication, cleanliness of the lubrication, speed, temperature, magnitude of the load and the bearing type.

The operating life of a bearing is the actual life achieved by the bearing and can be significantly different from the calculated life. Comparison with similar applications is the most accurate method for bearing life estimations.

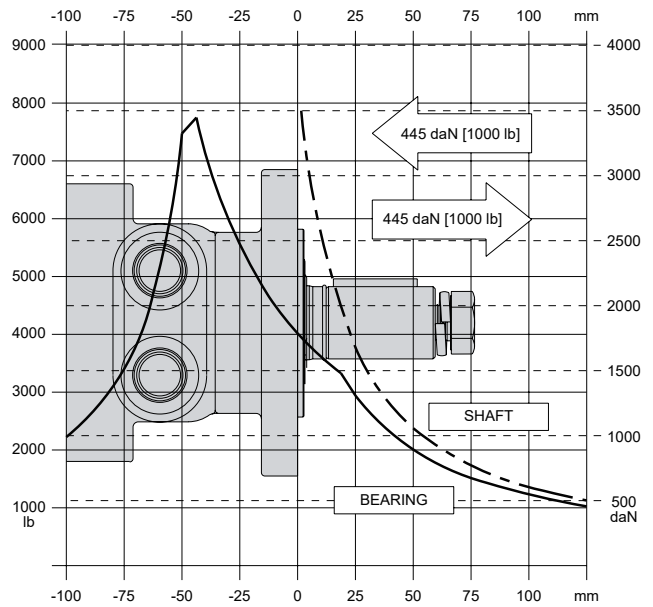

**EXAMPLE LOAD RATING FOR MECHANICALLY RETAINED NEEDLE ROLLER BEARINGS**

Bearing Life  $L_{10} = (C/P)^p [10^6 \text{ revolutions}]$   
 $L_{10}$  = nominal rating life  
 C = dynamic load rating  
 P = equivalent dynamic load  
 Life Exponent  $P = 10/3$  for needle bearings

BEARING LOAD MULTIPLICATION FACTOR TABLE			
RPM	FACTOR	RPM	FACTOR
50	1.23	500	0.62
100	1.00	600	0.58
200	0.81	700	0.56
300	0.72	800	0.50
400	0.66		

## VEHICLE DRIVE CALCULATIONS

When selecting a wheel drive motor for a mobile vehicle, a number of factors concerning the vehicle must be taken into consideration to determine the required maximum motor RPM, the maximum torque required and the maximum load each motor must support. The following sections contain the necessary equations to determine this criteria. An example is provided to illustrate the process.

### Sample application (vehicle design criteria)

vehicle description ..... 4 wheel vehicle  
 vehicle drive ..... 2 wheel drive  
 GVW ..... 1,500lbs.  
 weight over each drive wheel ..... 425 lbs.  
 rolling radius of tires ..... 16 in.  
 desired acceleration ..... 0-5 mph in 10 sec.  
 top speed ..... 5 mph  
 gradability ..... 20%  
 worst working surface ..... poor asphalt

### To determine maximum motor speed

$$\text{RPM} = \frac{2.65 \times \text{KPH} \times G}{r_m} \quad \text{RPM} = \frac{168 \times \text{MPH} \times G}{r_i}$$

Where:

MPH = max. vehicle speed (miles/hr)  
 KPH = max. vehicle speed (kilometers/hr)  
 r<sub>i</sub> = rolling radius of tire (inches)  
 G = gear reduction ratio (if none, G = 1)  
 r<sub>m</sub> = rolling radius of tire (meters)

**Example**  $\text{RPM} = \frac{168 \times 5 \times 1}{16} = 52.5$

### To determine maximum torque requirement of motor

To choose a motor(s) capable of producing enough torque to propel the vehicle, it is necessary to determine the Total Tractive Effort (TE) requirement for the vehicle. To determine the total tractive effort, the following equation must be used:

$$\text{TE} = \text{RR} + \text{GR} + \text{FA} + \text{DP} \text{ (lbs or N)}$$

Where:

TE = Total tractive effort  
 RR = Force necessary to overcome rolling resistance  
 GR = Force required to climb a grade  
 FA = Force required to accelerate  
 DP = Drawbar pull required

The components for this equation may be determined using the following steps:

### Step One: Determine Rolling Resistance

Rolling Resistance (RR) is the force necessary to propel a vehicle over a particular surface. It is recommended that the worst possible surface type to be encountered by the vehicle be factored into the equation.

$$\text{RR} = \frac{\text{GVW}}{1000} \times R \text{ (lb or N)}$$

Where:

GVW = gross (loaded) vehicle weight (lb or kg)  
 R = surface friction (value from Table 1)

**Example**  $\text{RR} = \frac{1500}{1000} \times 22 \text{ lbs} = 33 \text{ lbs}$

Table 1

Rolling Resistance	
Concrete (excellent).....	10
Concrete (good).....	15
Concrete (poor).....	20
Asphalt (good).....	12
Asphalt (fair).....	17
Asphalt (poor).....	22
Macadam (good).....	15
Macadam (fair).....	22
Macadam (poor).....	37
Cobbles (ordinary).....	55
Cobbles (poor).....	37
Snow (2 inch).....	25
Snow (4 inch).....	37
Dirt (smooth).....	25
Dirt (sandy).....	37
Mud.....	37 to 150
Sand (soft).....	60 to 150
Sand (dune).....	160 to 300

### Step Two: Determine Grade Resistance

Grade Resistance (GR) is the amount of force necessary to move a vehicle up a hill or "grade." This calculation must be made using the maximum grade the vehicle will be expected to climb in normal operation.

To convert incline degrees to % Grade:

$$\% \text{ Grade} = [\tan \text{ of angle (degrees)}] \times 100$$

$$\text{GR} = \frac{\% \text{ Grade}}{100} \times \text{GVW} \text{ (lb or N)}$$

**Example**  $\text{GR} = \frac{20}{100} \times 1500 \text{ lbs} = 300 \text{ lbs}$

**VEHICLE DRIVE CALCULATIONS**

**Step Three: Determine Acceleration Force**

Acceleration Force (FA) is the force necessary to accelerate from a stop to maximum speed in a desired time.

$$FA = \frac{MPH \times GVW \text{ (lb)}}{22 \times t} \qquad FA = \frac{KPH \times GVW \text{ (N)}}{35.32 \times t}$$

Where:

t = time to maximum speed (seconds)

**Example**  $FA = \frac{5 \times 1500 \text{ lbs}}{22 \times 10} = 34 \text{ lbs}$

**Step Four: Determine Drawbar Pull**

Drawbar Pull (DP) is the additional force, if any, the vehicle will be required to generate if it is to be used to tow other equipment. If additional towing capacity is required for the equipment, repeat steps one through three for the towable equipment and sum the totals to determine DP.

**Step Five: Determine Total Tractive Effort**

The Tractive Effort (TE) is the sum of the forces calculated in steps one through three above. On low speed vehicles, wind resistance can typically be neglected. However, friction in drive components may warrant the addition of 10% to the total tractive effort to insure acceptable vehicle performance.

$$TE = RR + GR + FA + DP \text{ (lb or N)}$$

**Example**  $TE = 33 + 300 + 34 + 0 \text{ (lbs)} = 367 \text{ lbs}$

**Step Six: Determine Motor Torque**

The Motor Torque (T) required per motor is the Total Tractive Effort divided by the number of motors used on the machine. Gear reduction is also factored into account in this equation.

$$T = \frac{TE \times ri}{M \times G} \text{ lb-in per motor} \qquad T = \frac{TE \times rm}{M \times G} \text{ Nm per motor}$$

Where:

M = number of driving motors

**Example**  $T = \frac{367 \times 16}{2 \times 1} \text{ lb-in/motor} = 2936 \text{ lb-in}$

**Step Seven: Determine Wheel Slip**

To verify that the vehicle will perform as designed in regards to tractive effort and acceleration, it is necessary to calculate wheel slip (TS) for the vehicle. In special cases, wheel slip may actually be desirable to prevent hydraulic system overheating and component breakage should the vehicle become stalled.

$$TS = \frac{W \times f \times ri}{G} \qquad TS = \frac{W \times f \times rm}{G}$$

(lb-in per motor)      (N-m per motor)

Where:

f = coefficient of friction (see table 2)

W = loaded vehicle weight over driven wheel (lb or N)

**Example**  $TS = \frac{425 \times .06 \times 16}{1} \text{ lb-in/motor} = 4080 \text{ lbs}$

Table 2

Coefficient of friction (f)	
Steel on steel.....	0.3
Rubber tire on dirt.....	0.5
Rubber tire on a hard surface .....	0.6 - 0.8
Rubber tire on cement.....	0.7

**To determine radial load capacity requirement of motor**

When a motor used to drive a vehicle has the wheel or hub attached directly to the motor shaft, it is critical that the radial load capabilities of the motor are sufficient to support the vehicle. After calculating the Total Radial Load (RL) acting on the motors, the result must be compared to the bearing/shaft load charts for the chosen motor to determine if the motor will provide acceptable load capacity and life.

$$RL = \sqrt{W^2 + \left(\frac{T}{ri}\right)^2} \text{ lb} \qquad RL = \sqrt{W^2 + \left(\frac{T}{rm}\right)^2} \text{ kg}$$

**Example**  $RL = \sqrt{425^2 + \left(\frac{2936}{16}\right)^2} = 463 \text{ lbs}$

Once the maximum motor RPM, maximum torque requirement, and the maximum load each motor must support have been determined, these figures may then be compared to the motor performance charts and to the bearing load curves to choose a series and displacement to fulfill the motor requirements for the application.

### INDUCED SIDE LOAD

In many cases, pulleys or sprockets may be used to transmit the torque produced by the motor. Use of these components will create a torque induced side load on the motor shaft and bearings. It is important that this load be taken into consideration when choosing a motor with sufficient bearing and shaft capacity for the application.

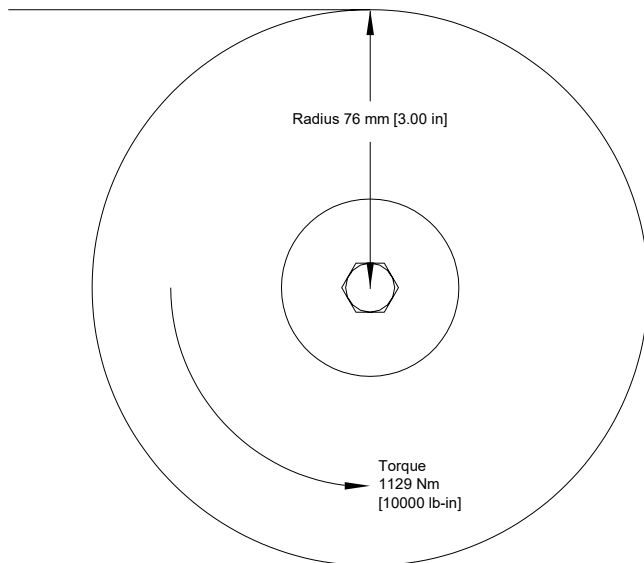

To determine the side load, the motor torque and pulley or sprocket radius must be known. Side load may be calculated using the formula below. The distance from the pulley/sprocket centerline to the mounting flange of the motor must also be determined. These two figures may then be compared to the bearing and shaft load curve of the desired motor to determine if the side load falls within acceptable load ranges.

$$\text{Side Load} = \frac{\text{Torque}}{\text{Radius}}$$

$$\text{Side Load} = 14855 \text{ N [33333 lbs]}$$

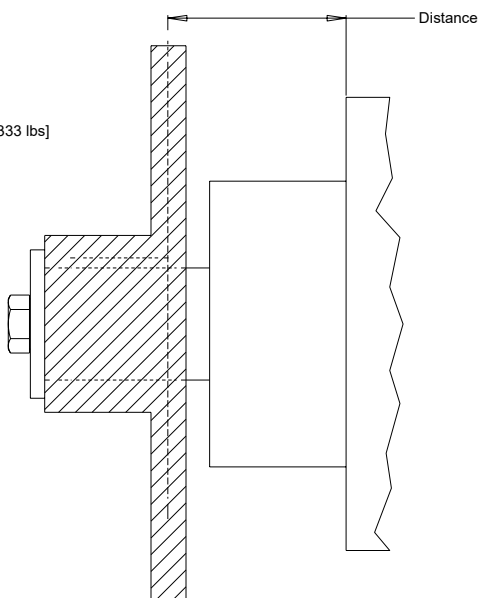

### HYDRAULIC EQUATIONS

Multiplication Factor	Abbrev.	Prefix
10 <sup>12</sup>	T	tera
10 <sup>9</sup>	G	giga
10 <sup>6</sup>	M	mega
10 <sup>3</sup>	K	kilo
10 <sup>2</sup>	h	hecto
10 <sup>1</sup>	da	deka
10 <sup>-1</sup>	d	deci
10 <sup>-2</sup>	c	centi
10 <sup>-3</sup>	m	milli
10 <sup>-6</sup>	u	micro
10 <sup>-9</sup>	n	nano
10 <sup>-12</sup>	p	pico
10 <sup>-15</sup>	f	femto
10 <sup>-18</sup>	a	atto

Theo. Speed (RPM) =

$$\frac{1000 \times \text{LPM}}{\text{Displacement (cm}^3/\text{rev)}} \quad \text{or} \quad \frac{231 \times \text{GPM}}{\text{Displacement (in}^3/\text{rev)}}$$

Theo. Torque (lb-in) =

$$\frac{\text{Bar} \times \text{Disp. (cm}^3/\text{rev)}}{20 \text{ pi}} \quad \text{or} \quad \frac{\text{PSI} \times \text{Displacement (in}^3/\text{rev)}}{6.28}$$

Power In (HP) =

$$\frac{\text{Bar} \times \text{LPM}}{600} \quad \text{or} \quad \frac{\text{PSI} \times \text{GPM}}{1714}$$

Power Out (HP) =

$$\frac{\text{Torque (Nm)} \times \text{RPM}}{9543} \quad \text{or} \quad \frac{\text{Torque (lb-in)} \times \text{RPM}}{63024}$$

**SHAFT NUT INFORMATION**

**35MM TAPERED SHAFTS**

M24 x 1.5 Thread

**A** Slotted Nut

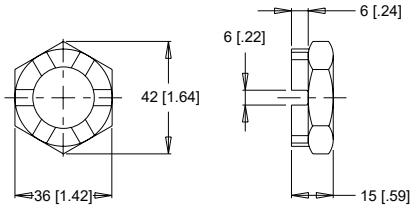

Torque Specifications: 32.5 daNm [240 ft.lb.]

**PRECAUTION**

The tightening torques listed with each nut should only be used as a guideline. Hubs may require higher or lower tightening torque depending on the material. Consult the hub manufacturer to obtain recommended tightening torque. To maximize torque transfer from the shaft to the hub, and to minimize the potential for shaft breakage, a hub with sufficient thickness must fully engage the taper length of the shaft.

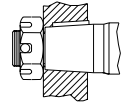

incorrect

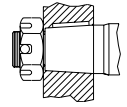

correct

**1" TAPERED SHAFTS**

3/4-28 Thread

**A** Slotted Nut

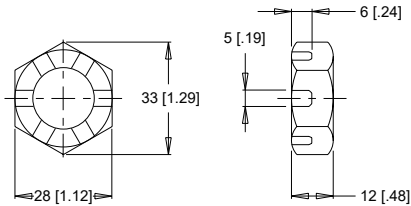

Torque Specifications: 20 - 23 daNm [150 - 170 ft.lb.]

**B** Lock Nut

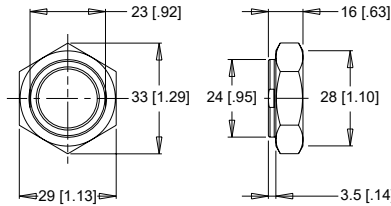

Torque Specifications: 24 - 27 daNm [180 - 200 ft.lb.]

**C** Solid Nut

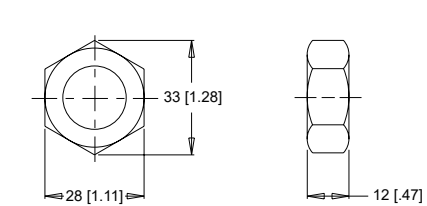

Torque Specifications: 20 - 23 daNm [150 - 170 ft.lb.]

**1-1/4" TAPERED SHAFTS**

1-20 Thread

**A** Slotted Nut

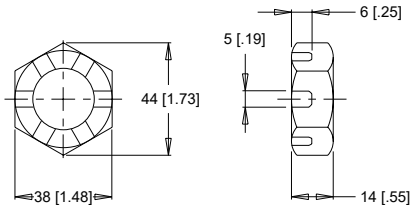

Torque Specifications: 38 daNm [280 ft.lb.] Max.

**B** Lock Nut

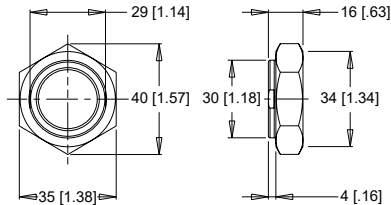

Torque Specifications: 33 - 42 daNm [240 - 310 ft.lb.]

**C** Solid Nut

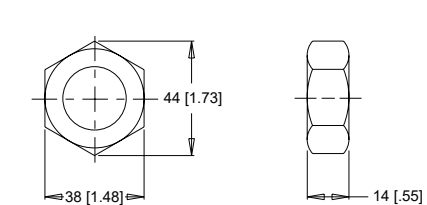

Torque Specifications: 38 daNm [280 ft.lb.] Max.

**1-3/8" & 1-1/2" TAPERED SHAFTS**

1 1/8-18 Thread

**A** Slotted Nut

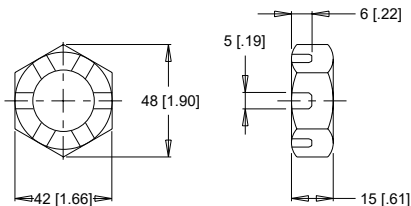

Torque Specifications: 41 - 54 daNm [300 - 400 ft.lb.]

**B** Lock Nut

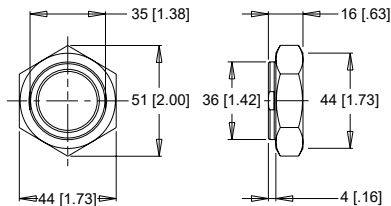

Torque Specifications: 34 - 48 daNm [250 - 350 ft.lb.]

**C** Solid Nut

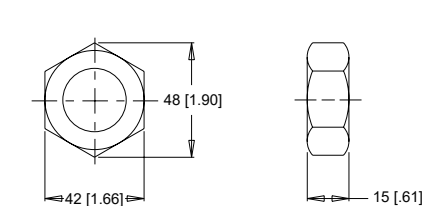

Torque Specifications: 41 - 54 daNm [300 - 400 ft.lb.]

## SPEED SENSORS

Impro Fluidtek offers both single and dual element speed sensor options providing a number of benefits to users by incorporating the latest advancements in sensing technology and materials. The single element sensors provide 50 pulses per revolution with the dual element providing 100 pulses per revolution.” Higher resolution is especially beneficial for slow speed applications, where more information is needed for smooth and accurate control. The dual sensor option also provides a direction signal allowing end-users to monitor the direction of shaft rotation.

Unlike competitive designs that breach the high pressure area of the motor to add the sensor, the Impro Fluidtek speed sensor option utilizes an add-on flange to locate all sensor components outside the high pressure operating environment. This eliminates the potential leak point common to competitive designs. Many improvements were made to the sensor flange including changing the material from cast iron to acetal resin, incorporating a Buna-N shaft seal internal to the flange, and providing a grease zerk, which allows the user to fill the sensor cavity with grease. These improvements enable the flange to withstand the rigors of harsh environments.

Another important feature of the new sensor flange is that it is self-centering, which allows it to remain concentric to the magnet rotor. This produces a consistent mounting location for the new sensor module, eliminating the need to adjust

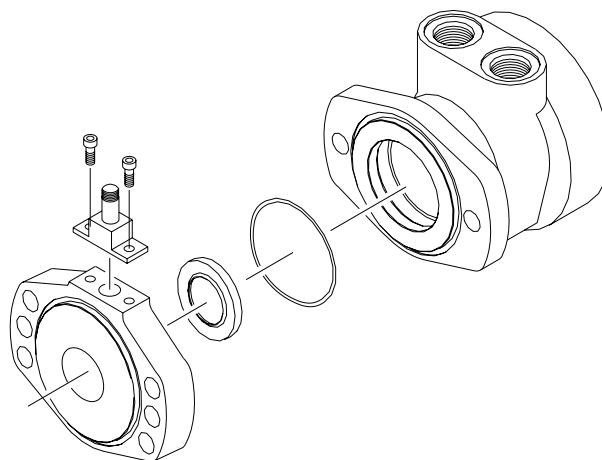

the air gap between the sensor and magnet rotor. The o-ring sealed sensor module attaches to the sensor flange with two small screws, allowing the sensor to be serviced or upgraded in the field in under one minute. This feature is especially valuable for mobile applications where machine downtime is costly. The sensor may also be serviced without exposing the hydraulic circuit to the atmosphere. Another advantage of the self-centering flange is that it allows users to rotate the sensor to a location best suited to their application. This feature is not available on competitive designs, which fix the sensor in one location in relationship to the motor mounting flange.

## FEATURES / BENEFITS

- Grease fitting allows sensor cavity to be filled with grease for additional protection.
- Internal extruder seal protects against environmental elements.
- M12 or weatherpack connectors provide installation flexibility.
- Dual element sensor provides up to 100 pulses per revolution and directional sensing.
- Modular sensor allows quick and easy servicing.
- Acetal resin flange is resistant to moisture, chemicals, oils, solvents and greases.
- Self-centering design eliminates need to set magnet-to-sensor air gap.
- Protection circuitry

## SENSOR OPTIONS

### Z - 4-pin M12 male connector

This option has 50 pulses per revolution on all series. This option will not detect direction.

### Y - 3-pin male weatherpack connector\*

This option has 50 pulses per revolution on all series. This option will not detect direction.

### X - 4-pin M12 male connector

This option has 100 pulses per revolution on all series. This option will detect direction.

### W - 4-pin male weatherpack connector\*

This option has 100 pulses per revolution on all series. This option will detect direction.

\*These options include a 610mm [2 ft] cable.

## SPEED SENSORS

### SINGLE ELEMENT SENSOR - Y & Z

Supply voltages ..... 7.5-24 Vdc  
 Maximum output off voltage ..... 24 V  
 Maximum continuous output current ..... < 25 ma  
 Signal levels (low, high) ..... 0.8 to supply voltage  
 Operating Temp ..... -30°C to 83°C [-22°F to 181°F]

### DUAL ELEMENT SENSOR - X & W

Supply voltages ..... 7.5-18 Vdc  
 Maximum output off voltage ..... 18 V  
 Maximum continuous output current ..... < 20 ma  
 Signal levels (low, high) ..... 0.8 to supply voltage  
 Operating Temp ..... -30°C to 83°C [-22°F to 181°F]

### SENSOR CONNECTORS

Z Option

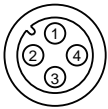

PIN		
1	positive	brown or red
2	n/a	white
3	negative	blue
4	pulse out	black

X Option

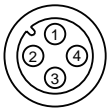

PIN		
1	positive	brown or red
2	direction out	white
3	negative	blue
4	pulse out	black

Y Option

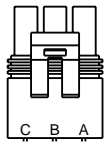

PIN		
A	positive	brown or red
B	negative	blue
C	pulse out	black
D	n/a	white

W Option

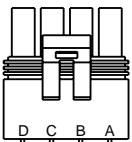

PIN		
A	positive	brown or red
B	negative	blue
C	pulse out	black
D	direction out	white

### PROTECTION CIRCUITRY

The single element sensor has been improved and incorporates protection circuitry to avoid electrical damage caused by:

- reverse battery protection
- overvoltage due to power supply spikes and surges (60 Vdc max.)
- power applied to the output lead

The protection circuit feature will help “save” the sensor from damage mentioned above caused by:

- faulty installation wiring or system repair
- wiring harness shorts/opens due to equipment failure or harness damage resulting from accidental conditions (i.e. severed or grounded wire, ice, etc.)
- power supply spikes and surges caused by other electrical/electronic components that may be intermittent or damaged and “loading down” the system.

While no protection circuit can guarantee against any and all fault conditions. The single element sensor from Impro Fluidtek with protection circuitry is designed to handle potential hazards commonly seen in real world applications.

Unprotected versions are also available for operation at lower voltages down to 4.5V.

### FREE TURNING ROTOR

The ‘AC’ option or “Free turning” option refers to a specially prepared rotor assembly. This rotor assembly has increased clearance between the rotor tips and rollers allowing it to turn more freely than a standard rotor assembly. For spool valve motors, additional clearance is also provided between the shaft and housing bore. The ‘AC’ option is available for all motor series and displacements.

There are several applications and duty cycle conditions where ‘AC’ option performance characteristics can be beneficial. In continuous duty applications that require high flow/high RPM operation, the benefits are twofold. The additional clearance helps to minimize internal pressure drop at high flows. This clearance also provides a thicker oil film at metal to metal contact areas and can help extend the life of the motor in high RPM or even over speed conditions. The ‘AC’ option should be considered for applications that require continuous operation above 57 LPM [15 GPM] and/or 300 RPM. Applications that are subject to pressure spikes due to frequent reversals or shock loads can also benefit by specifying the ‘AC’ option. The additional clearance serves to act as a buffer against spikes, allowing them to be bypassed through the motor rather than being absorbed and transmitted through the drive link to the output shaft. The trade-off for achieving these benefits is a slight loss of volumetric efficiency at high pressures.

## INTERNAL DRAIN

The internal drain is standard on all WD, WP, WR, and WS360. Typically, a separate drain line must be installed to direct case leakage of the motor back to the reservoir when using, WS365/366. However, the internal drain option eliminates the need for a separate drain line through the installation of two check valves in the motor. This simplifies plumbing requirements for the motor.

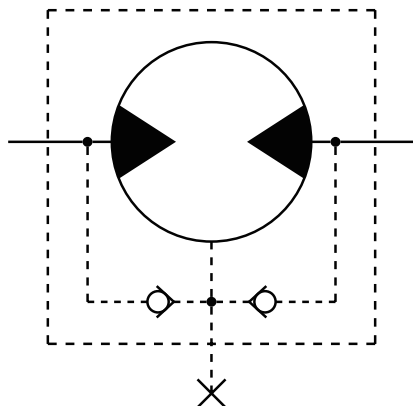

The two check valves connect the case area of the motor to each port of the endcover. During normal motor operation, pressure in the input and return lines of the motor close the check valves. However, when the pressure in the case of the motor is greater than that of the return line, the check valve between the case and low pressure line opens, allowing the case leakage to flow into the return line. Since the operation of the check valves is dependent upon a pressure differential, the internal drain option operates in either direction of motor rotation.

Although this option can simplify many motor installations, precautions must be taken to insure that return line pressure remains below allowable levels (see table below) to insure proper motor operation and life. If return line pressure is higher than allowable, or experiences pressure spikes, this pressure may feed back into the motor, possibly causing catastrophic seal failure. Installing motors with internal drains in series is not recommended unless overall pressure drop over all motors is below the maximum allowable backpressure as listed in the chart below. If in doubt, contact your authorized Impro Fluidtek representative.

MAXIMUM ALLOWABLE BACK PRESSURE		
Series	Cont. bar [psi]	Inter. bar [psi]
WH	69 [1000]	103 [1500]
WT	21 [300]	34 [500]
Brakes	34 [500]	34 [500]

## HYDRAULIC DECLUTCH

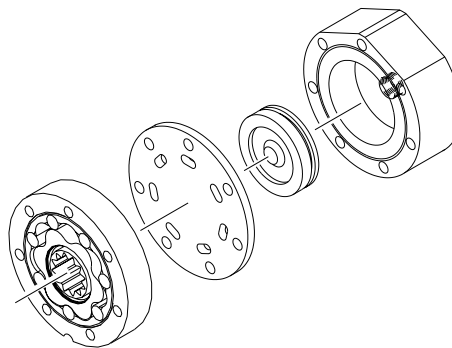

The declutch or 'AE' option, available on the RE and CE Series motors, has been specifically designed for applications requiring the motor to have the ability to "freewheel" when not pressurized. By making minor changes to internal components, the torque required to turn the output shaft is minimal. Selection of this option allows freewheeling speeds up to 1,000 RPM\* depending on the displacement of the motor and duty cycle of the application.

To enable the motor to perform this function, the standard rotor assembly is replaced with a freeturn rotor assembly. Next, the standard balance plate and endcover is replaced with a special wear plate and ported endcover. The wear plate features seven holes that connect the stator pockets to each other. The ported endcover features a movable piston capable of sealing the seven holes in the wear plate.

When standard motor function is required, pressure is supplied to the endcover port, moving the piston against the wear plate. This action seals the seven holes allowing the motor to function as normal. However, when pressure is removed from the endcover port, the pressure created by the turning rotor assembly pushes the piston away from the wear plate, opening the rotor pockets to each other. In this condition, oil may circulate freely within the rotor and endcover assemblies, allowing the rotor assembly to rotate freely within the motor.

This option is especially useful in applications ranging from winch drives to towable wheel drives. Depending on the valves and hydraulic circuitry, operation of the freewheel function may be manually or automatically selected. A basic schematic is shown to the right.

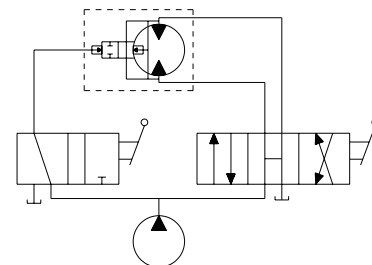

► The 1,000 RPM rating was based on smaller displacement options with forced flow flushing through the motor to provide cooling.

## VALVE CAVITY

The valve cavity option provides a cost effective way to incorporate a variety of cartridge valves integral to the motor. The valve cavity is a standard 10 series 2-way cavity that accepts numerous cartridge valves, including over-running check valves, relief cartridges, flow control valves, pilot operated check fuses, and high pressure shuttle valves. Installation of a relief cartridge into the cavity provides an extra margin of safety for applications encountering frequent pressure spikes. Relief cartridges from 69 to 207 bar [1000 to 3000 psi] may also be factory installed.

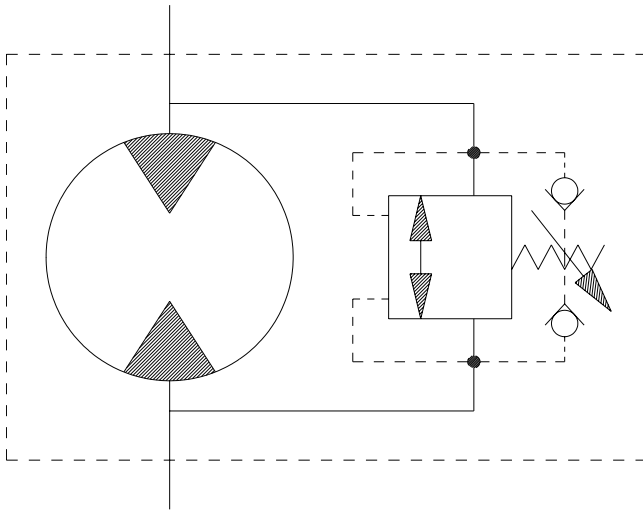

For basic systems with fixed displacement pumps, either manual or motorized flow control valves may be installed into the valve cavity to provide a simple method for controlling motor speed. It is also possible to incorporate the speed sensor option and a programmable logic controller with a motorized flow control valve to create a closed loop, fully automated speed control system. For motors with internal brakes, a shuttle valve cartridge may be installed into the cavity to provide a simple, fully integrated method for supplying release pressure to the pilot line to actuate an integral brake. To discuss other alternatives for the valve cavity option, contact an authorized Impro Fluidtek distributor.

## SLINGER SEAL

Slinger seals are available on select series offered by Impro Fluidtek. Slinger seals offer extended shaft/shaft seal protection by prevented a buildup of material around the circumference of the shaft which can lead to premature shaft seal failures. The Impro Fluidtek slinger seals are designed to be larger in diameter than competitive products, providing greater surface speed and 'slinging action'.

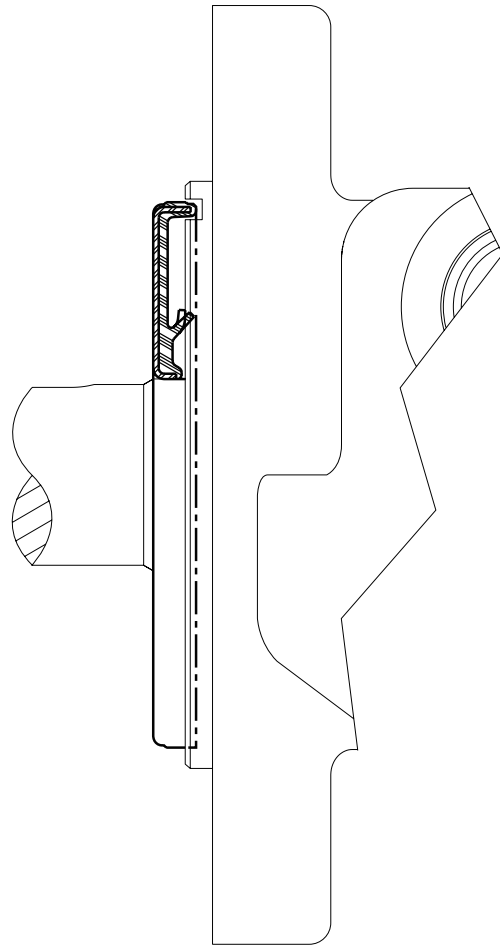

Slinger seals are also available on 4-hole flange mounts on select series. Contact a Impro Fluidtek Customer Service Representative for additional information.

**OVERVIEW**

The WH Series motor features a case drain design, making it an ideal choice for medium-duty applications with high duty cycles or frequent direction reversals. This design offers several advantages, such as lowering pressure on the shaft seal and facilitating a cooling loop for the system. Additionally, the case flow helps lubricate essential drive components, enhancing motor longevity. An internal drain option is also available. The motor incorporates a laminated manifold and a three-zone orbiting valve, resulting in improved overall efficiency and greater usable power. Furthermore, a steel-faced seal in the orbiting valve minimizes the risk of seal extrusion or melting, which can occur in competing models.

**FEATURES / BENEFITS**

- Three bearing options available, enabling the load-carrying capabilities of the motor to be tailored to specific applications.
- The heavy-duty drive link stands out as the most robust in its category, featuring case flow lubrication that minimizes wear and extends its lifespan.
- Three-zone orbiting valve accurately controls oil flow, delivering outstanding volumetric efficiency.
- The rubber-energized steel face seal is designed to withstand high pressure and temperature without extruding or melting.
- Standard case drain allows reduced pressure on the shaft seal while maintaining driveline lubrication for maximum motor life.

**TYPICAL APPLICATIONS**

Medium-duty wheel drives, augers, mixers, winch drives, swing drives, grapple heads, feed rollers, broom drives, chippers, mining equipment, forestry equipment and more

**SPECIFICATIONS**

CODE	Displacement cm <sup>3</sup> [in <sup>3</sup> /rev]	Max. Speed rpm		Max. Flow lpm [gpm]		Max. Torque Nm [lb-in]		Max. Pressure bar [psi]		
		cont.	inter.	cont.	inter.	cont.	inter.	cont.	inter.	peak
200	204 [12.4]	465	558	95 [25]	114 [30]	558 [4936]	653 [5778]	207 [3000]	241 [3500]	276 [4000]
260	261 [15.9]	362	434	95 [25]	114 [30]	746 [6598]	868 [7677]	207 [3000]	241 [3500]	276 [4000]
300	300 [18.3]	315	378	95 [25]	114 [30]	846 [7485]	978 [8637]	207 [3000]	241 [3500]	276 [4000]
350	348 [21.2]	272	326	95 [25]	114 [30]	1018 [9010]	1172 [10367]	207 [3000]	241 [3500]	276 [4000]
375	375 [22.8]	253	303	95 [25]	114 [30]	1088 [9628]	1246 [11029]	207 [3000]	241 [3500]	276 [4000]
470	465 [28.3]	204	244	95 [25]	114 [30]	1142 [10106]	1362 [12056]	173 [2500]	207 [3000]	241 [3500]
540	536 [32.7]	176	211	95 [25]	114 [30]	1038 [9188]	1280 [11325]	138 [2000]	173 [2500]	207 [3000]
750	748 [45.6]	126	151	95 [25]	114 [30]	1040 [9207]	1399 [12382]	103 [1500]	138 [2000]	172 [2500]

► Performance data is typical. Performance of production units varies slightly from one motor to another. See page 6 for additional information on product testing. Running at intermittent ratings should not exceed 10% of every minute of operation.

**SERIES DESCRIPTIONS**

600 - Hydraulic Motor  
Standard

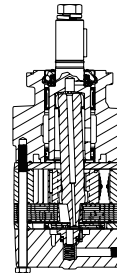

620 - Hydraulic Motor  
With Medium Duty Bearing

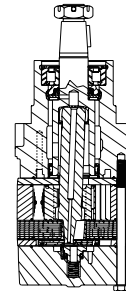

630 - Hydraulic Motor  
With Heavy Duty Bearing

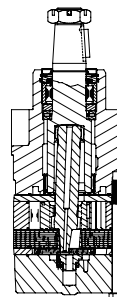

**DISPLACEMENT PERFORMANCE**

		Pressure - bar [psi]						Max. Cont.	Max. Inter.	
<b>200</b>		17 [250]	35 [500]	69 [1000]	104 [1500]	138 [2000]	173 [2500]	207 [3000]	241 [3500]	
204 cm <sup>3</sup> [12.4 in <sup>3</sup> ] / rev										
		Torque - Nm [lb-in], Speed rpm						Intermittent Ratings - 10% of Operation		
Flow - lpm [gpm]	2 [0.5]	38 [335] 7	77 [683] 4							10
	4 [1]	39 [342] 16	85 [748] 15	174 [1543] 13	258 [2284] 9	329 [2913] 5				19
	8 [2]	38 [339] 35	90 [795] 34	178 [1579] 32	271 [2396] 28	361 [3192] 23	454 [4016] 16	519 [4594] 11	562 [4977] 3	38
	15 [4]	36 [323] 73	85 [749] 72	178 [1576] 69	283 [2506] 64	378 [3346] 57	459 [4059] 54	555 [4909] 44	636 [5625] 35	75
	23 [6]		78 [690] 110	177 [1562] 106	273 [2413] 101	362 [3202] 97	462 [4085] 89	551 [4880] 80	645 [5711] 70	112
	30 [8]		74 [654] 148	172 [1518] 145	268 [2368] 141	357 [3156] 133	469 [4154] 126	558 [4936] 117	653 [5778] 105	150
	38 [10]			168 [1491] 184	260 [2301] 178	349 [3091] 174	444 [3933] 167	541 [4783] 156	638 [5646] 144	187
	45 [12]			156 [1381] 221	255 [2256] 215	350 [3096] 209	450 [3985] 204	542 [4793] 199	634 [5607] 179	224
	53 [14]			150 [1332] 259	251 [2219] 254	330 [2919] 250	435 [3850] 241	526 [4653] 231	638 [5643] 213	261
	61 [16]			133 [1180] 297	241 [2129] 293	336 [2970] 286	430 [3803] 278	522 [4616] 276	613 [5423] 256	299
	68 [18]			122 [1082] 335	227 [2012] 332	328 [2899] 325	417 [3692] 319	510 [4510] 310	602 [5329] 298	336
	76 [20]			112 [993] 372	214 [1897] 371	309 [2732] 365	401 [3547] 356	496 [4391] 348	587 [5198] 337	373
	83 [22]				199 [1757] 409	303 [2680] 404	384 [3401] 396	493 [4358] 384	579 [5121] 374	410
	91 [24]				184 [1625] 447	285 [2526] 443	380 [3366] 433	474 [4192] 423	562 [4970] 417	448
95 [25]				166 [1472] 465	277 [2453] 461	367 [3244] 454	463 [4101] 443	560 [4953] 432	466	
114 [30]					219 [1935] 558	332 [2934] 553			559	

**Overall Efficiency** - 70 - 100%  40 - 69%  0 - 39%

**Rotor Width**

17.3 [.682]	56 [494]	112 [987]	223 [1975]	335 [2962]	446 [3949]	558 [4936]	669 [5924]	781 [6911]
-------------	----------	-----------	------------	------------	------------	------------	------------	------------

mm [in]

Displacement tested at 54°C [129°F] with an oil viscosity of 46cSt [213 SUS]

		Pressure - bar [psi]						Max. Cont.	Max. Inter.	
<b>260</b>		17 [250]	35 [500]	69 [1000]	104 [1500]	138 [2000]	173 [2500]	207 [3000]	241 [3500]	
261 cm <sup>3</sup> [15.9 in <sup>3</sup> ] / rev										
		Torque - Nm [lb-in], Speed rpm						Intermittent Ratings - 10% of Operation		
Flow - lpm [gpm]	2 [0.5]	47 [417] 5	109 [962] 4							8
	4 [1]	51 [454] 13	110 [972] 11	238 [2104] 11	355 [3139] 8	460 [4074] 5				15
	8 [2]	52 [462] 28	113 [1004] 27	242 [2145] 25	367 [3244] 22	485 [4292] 18	603 [5334] 14	715 [6323] 11		30
	15 [4]	49 [430] 57	111 [985] 56	239 [2115] 54	367 [3247] 51	491 [4343] 45	619 [5474] 41	746 [6598] 36	859 [7600] 30	59
	23 [6]	44 [391] 87	107 [950] 86	234 [2067] 83	364 [3225] 78	487 [4311] 72	617 [5458] 67	738 [6530] 60	854 [7557] 54	88
	30 [8]		100 [884] 115	228 [2016] 113	355 [3146] 107	478 [4230] 103	612 [5418] 95	733 [6487] 89	868 [7677] 82	117
	38 [10]		90 [797] 145	220 [1947] 143	348 [3080] 138	468 [4143] 132	605 [5351] 123	734 [6498] 115	852 [7541] 107	146
	45 [12]		84 [748] 174	212 [1877] 172	340 [3011] 168	463 [4094] 162	596 [5272] 152	722 [6390] 143	845 [7481] 133	175
	53 [14]		71 [631] 203	205 [1813] 201	330 [2921] 198	452 [4004] 185	587 [5195] 179	706 [6244] 173	846 [7491] 163	204
	61 [16]			191 [1688] 231	317 [2807] 228	444 [3927] 223	574 [5077] 214	703 [6221] 203	824 [7291] 196	233
	68 [18]			174 [1540] 261	305 [2698] 256	429 [3798] 251	560 [4952] 246	690 [6111] 230	815 [7214] 220	262
	76 [20]			156 [1383] 290	289 [2558] 289	418 [3700] 282	544 [4817] 268	675 [5977] 262	810 [7166] 247	291
	83 [22]			143 [1270] 319	275 [2431] 317	405 [3585] 313	533 [4717] 300	659 [5828] 293	787 [6961] 277	320
	91 [24]			131 [1158] 348	255 [2253] 346	387 [3421] 342	515 [4554] 333	613 [5421] 322	769 [6805] 311	349
95 [25]				239 [2115] 362	373 [3301] 357	505 [4471] 348	628 [5559] 342	772 [6832] 328	364	
114 [30]				157 [1388] 434	298 [2637] 432	426 [3768] 427			436	

**Overall Efficiency** - 70 - 100%  40 - 69%  0 - 39%

**Rotor Width**

22.1 [.872]	72 [633]	143 [1266]	286 [2532]	429 [3798]	572 [5064]	715 [6330]	858 [7596]	1001 [8861]
-------------	----------	------------	------------	------------	------------	------------	------------	-------------

mm [in]

Displacement tested at 54°C [129°F] with an oil viscosity of 46cSt [213 SUS]

▶ Performance data is typical. Performance of production units varies slightly from one motor to another. See page 6 for additional information on product testing.

**DISPLACEMENT PERFORMANCE**

		Pressure - bar [psi]						Max. Cont.	Max. Inter.			
<b>300</b>		17 [250]	35 [500]	69 [1000]	104 [1500]	138 [2000]	173 [2500]	207 [3000]	241 [3500]			
300 cm <sup>3</sup> [18.3 in <sup>3</sup> ] / rev												
		Torque - Nm [lb-in], Speed rpm						Intermittent Ratings - 10% of Operation				
Flow - lpm [gpm]	Max. Max. Inter. Cont.	2 [0.5]	58 [509] 5	117 [1039] 4	253 [2236] 4							7
		4 [1]	58 [517] 12	122 [1081] 11	266 [2353] 11	384 [3396] 11	509 [4501] 9	633 [5599] 9				13
		8 [2]	58 [516] 25	128 [1134] 24	267 [2360] 24	404 [3572] 23	553 [4893] 22	683 [6045] 21	813 [7198] 20	917 [8112] 20		26
		15 [4]	56 [491] 50	132 [1173] 49	274 [2425] 49	417 [3691] 48	553 [4890] 47	703 [6225] 44	836 [7397] 43	962 [8513] 42		51
		23 [6]	53 [466] 75	123 [1092] 75	269 [2384] 74	406 [3590] 73	559 [4949] 71	701 [6207] 69	831 [7356] 66	954 [8445] 63		76
		30 [8]	44 [386] 100	117 [1036] 99	256 [2263] 97	419 [3710] 96	548 [4847] 95	707 [6256] 93	846 [7485] 88	974 [8619] 85		101
		38 [10]		107 [947] 126	251 [2222] 126	390 [3448] 125	561 [4961] 121	691 [6119] 119	836 [7396] 113	976 [8637] 109		127
		45 [12]		95 [841] 151	238 [2108] 150	400 [3538] 150	529 [4685] 149	696 [6160] 144	833 [7371] 140	969 [8573] 135		152
		53 [14]		84 [748] 176	232 [2053] 175	366 [3237] 174	530 [4688] 173	676 [5978] 168	825 [7302] 164	964 [8533] 158		177
		61 [16]		71 [629] 201	217 [1920] 200	370 [3277] 198	508 [4494] 197	654 [5786] 196	803 [7104] 187	952 [8428] 182		202
		68 [18]			202 [1792] 227	339 [2996] 226	503 [4448] 226	645 [5712] 221	781 [6914] 214	933 [8253] 211		228
		76 [20]			184 [1631] 252	326 [2887] 251	467 [4129] 249	635 [5619] 244	772 [6831] 236	927 [8205] 230		253
		83 [22]			164 [1449] 277	308 [2726] 275	446 [3943] 274	604 [5346] 271	745 [6592] 269	896 [7926] 267		278
		91 [24]			147 [1304] 302	286 [2535] 301	437 [3871] 300	580 [5137] 296	723 [6401] 293	861 [7620] 285		303
95 [25]			116 [1024] 315	291 [2574] 314	441 [3902] 312	575 [5085] 310	707 [6255] 309	848 [7500] 302		316		
114 [30]				204 [1805] 378	347 [3067] 376	499 [4416] 370				379		

Overall Efficiency - 70 - 100%  40 - 69%  0 - 39%

**Rotor Width**

25.4 [1.000]

mm [in]

Theoretical Torque - Nm [lb-in]

82 [729]	165 [1457]	329 [2914]	494 [4371]	659 [5828]	823 [7285]	988 [8742]	1152 [10199]
----------	------------	------------	------------	------------	------------	------------	--------------

Displacement tested at 54°C [129°F] with an oil viscosity of 46cSt [213 SUS]

		Pressure - bar [psi]						Max. Cont.	Max. Inter.		
<b>350</b>		17 [250]	35 [500]	69 [1000]	104 [1500]	138 [2000]	173 [2500]	207 [3000]	241 [3500]		

		Torque - Nm [lb-in], Speed rpm						Intermittent Ratings - 10% of Operation				
Flow - lpm [gpm]	Max. Max. Inter. Cont.	2 [0.5]	69 [606] 4	140 [1243] 3	262 [2318] 2							6
		4 [1]	75 [660] 10	153 [1350] 9	309 [2733] 7	454 [4014] 6						11
		8 [2]	75 [667] 21	158 [1395] 20	325 [2880] 17	489 [4326] 16	647 [5727] 14	784 [6937] 13	917 [8119] 11			22
		15 [4]	73 [648] 43	159 [1405] 42	333 [2943] 38	502 [4443] 36	677 [5988] 33	830 [7342] 31	984 [8704] 29	1123 [9935] 26		44
		23 [6]	67 [594] 65	152 [1346] 63	328 [2901] 61	502 [4439] 55	670 [5926] 51	841 [7444] 49	1010 [8940] 49	1155 [10220] 46		66
		30 [8]	56 [494] 87	143 [1268] 85	317 [2808] 83	494 [4368] 78	678 [6002] 72	833 [7376] 67	1018 [9010] 65	1172 [10367] 65		88
		38 [10]		129 [1141] 108	305 [2700] 105	477 [4219] 99	655 [5798] 92	830 [7345] 88	994 [8801] 85	1159 [10260] 83		109
		45 [12]		121 [1068] 130	291 [2578] 128	465 [4113] 122	641 [5672] 115	817 [7231] 107	991 [8766] 101	1169 [10342] 100		131
		53 [14]		103 [907] 151	275 [2437] 148	452 [4001] 145	630 [5572] 136	815 [7212] 130	972 [8604] 123	1162 [10284] 115		153
		61 [16]		85 [755] 174	258 [2281] 172	431 [3818] 168	609 [5390] 161	790 [6991] 152	983 [8696] 144	1141 [10099] 136		175
		68 [18]		66 [587] 196	246 [2174] 193	432 [3823] 190	583 [5161] 185	768 [6800] 171	944 [8355] 164	1131 [10012] 159		197
		76 [20]			223 [1969] 217	391 [3459] 211	568 [5026] 206	750 [6637] 196	925 [8186] 185	1101 [9742] 176		218
		83 [22]			193 [1704] 239	372 [3293] 236	545 [4825] 230	724 [6408] 219	909 [8049] 209	1092 [9666] 198		240
		91 [24]			169 [1492] 261	349 [3085] 257	537 [4755] 253	698 [6179] 243				262
95 [25]				325 [2874] 272	507 [4491] 265	687 [6082] 254				273		
114 [30]				255 [2258] 326	429 [3796] 320	605 [5354] 315				327		

Overall Efficiency - 70 - 100%  40 - 69%  0 - 39%

**Rotor Width**

39.4 [1.553]

mm [in]

Theoretical Torque - Nm [lb-in]

95 [844]	191 [1688]	381 [3376]	572 [5064]	763 [6752]	954 [8439]	1144 [10127]	1335 [11815]
----------	------------	------------	------------	------------	------------	--------------	--------------

Displacement tested at 54°C [129°F] with an oil viscosity of 46cSt [213 SUS]

▶ Performance data is typical. Performance of production units varies slightly from one motor to another. See page 6 for additional information on product testing.

**DISPLACEMENT PERFORMANCE**

		Pressure - bar [psi]						Max. Cont.	Max. Inter.		
<b>375</b>		17 [250]	35 [500]	69 [1000]	104 [1500]	138 [2000]	173 [2500]	207 [3000]	241 [3500]		
375 cm <sup>3</sup> [22.8 in <sup>3</sup> ] / rev											
		Torque - Nm [lb-in], Speed rpm						Intermittent Ratings - 10% of Operation			
Flow - lpm [gpm]	Max. Max. Inter. Cont.	2 [0.5]	69 [611] 4							6	
		4 [1]	74 [651] 9	161 [1425] 8	330 [2920] 8	494 [4369] 7	653 [5783] 6	823 [7283] 5		11	
		8 [2]	76 [676] 20	173 [1527] 19	354 [3133] 18	518 [4582] 17	685 [6065] 15	860 [7611] 13	1021 [9038] 13		21
		15 [4]	73 [649] 40	158 [1399] 40	350 [3098] 38	535 [4731] 37	706 [6250] 34	883 [7814] 32	1032 [9130] 30	1191 [10541] 30	41
		23 [6]	66 [588] 60	159 [1407] 60	346 [3058] 59	547 [4841] 57	712 [6300] 54	899 [7956] 49	1080 [9561] 47	1231 [10898] 45	61
		30 [8]	57 [502] 81	147 [1301] 80	337 [2980] 79	537 [4749] 77	700 [6192] 74	898 [7948] 70	1088 [9628] 65	1236 [10941] 62	82
		38 [10]		134 [1190] 101	323 [2856] 100	510 [4512] 99	694 [6139] 95	887 [7849] 90	1066 [9437] 85	1246 [11029] 79	102
		45 [12]		124 [1097] 121	309 [2730] 120	496 [4385] 119	679 [6009] 114	883 [7817] 109	1073 [9493] 104	1244 [11010] 99	122
		53 [14]		109 [961] 141	290 [2563] 140	477 [4217] 138	680 [6016] 136	854 [7556] 130	1041 [9214] 123	1230 [10888] 117	142
		61 [16]		82 [728] 162	267 [2362] 161	453 [4005] 159	637 [5641] 157	846 [7489] 150	1041 [9209] 144	1209 [10702] 136	163
		68 [18]			248 [2198] 182	434 [3842] 180	619 [5474] 175	812 [7190] 171	1002 [8864] 165	1148 [10161] 162	183
		76 [20]			229 [2026] 202	416 [3685] 201	600 [5309] 199	790 [6994] 192	979 [8664] 183	1145 [10137] 180	203
		83 [22]			199 [1764] 222	385 [3406] 221	572 [5065] 219	761 [6738] 215	953 [8435] 210	1111 [9834] 201	223
		91 [24]			168 [1490] 243	362 [3204] 241	566 [5007] 240	731 [6471] 235			244
		95 [25]				347 [3073] 253	554 [4905] 250	721 [6384] 245			254
		114 [30]				261 [2314] 303	440 [3891] 301	623 [5514] 300			304

Overall Efficiency - 70 - 100%  40 - 69%  0 - 39%

Theoretical Torque - Nm [lb-in]

31.8 [1.252]	103 [908]	205 [1815]	410 [3631]	615 [5446]	821 [7261]	1026 [9076]	1231 [10892]	1436 [12707]
--------------	-----------	------------	------------	------------	------------	-------------	--------------	--------------

mm [in]

Displacement tested at 54°C [129°F] with an oil viscosity of 46cSt [213 SUS]

		Pressure - bar [psi]						Max. Cont.	Max. Inter.		
<b>470</b>		17 [250]	35 [500]	69 [1000]	104 [1500]	138 [2000]	173 [2500]	207 [3000]			
465 cm <sup>3</sup> [28.3 in <sup>3</sup> ] / rev											
		Torque - Nm [lb-in], Speed rpm						Intermittent Ratings - 10% of Operation			
Flow - lpm [gpm]	Max. Max. Inter. Cont.	2 [0.5]	92 [815] 3	195 [1723] 2	374 [3306] 1					5	
		4 [1]	109 [967] 7	188 [1661] 6	418 [3701] 5	615 [5447] 4				9	
		8 [2]	99 [875] 15	217 [1924] 14	440 [3892] 13	668 [5910] 12	871 [7709] 9	1066 [9436] 7	1227 [10855] 5		17
		15 [4]	93 [825] 32	213 [1887] 30	441 [3906] 29	688 [6086] 28	907 [8027] 25	1131 [10008] 22	1343 [11886] 18		33
		23 [6]	85 [751] 48	200 [1771] 48	434 [3841] 46	686 [6074] 44	906 [8017] 40	1141 [10098] 35	1362 [12056] 30		49
		30 [8]	72 [635] 65	186 [1645] 64	422 [3738] 63	659 [5834] 61	889 [7871] 58	1142 [10106] 50	1352 [11963] 45		66
		38 [10]	53 [472] 81	169 [1493] 80	404 [3579] 79	639 [5657] 77	874 [7734] 74	1115 [9871] 66	1351 [11958] 59		82
		45 [12]		152 [1348] 97	402 [3561] 96	608 [5377] 94	855 [7563] 89	1111 [9836] 82	1340 [11861] 76		98
		53 [14]		133 [1175] 114	364 [3221] 113	598 [5292] 112	833 [7374] 107	1090 [9643] 98	1319 [11673] 90		115
		61 [16]		103 [910] 130	333 [2947] 129	569 [5037] 128	803 [7110] 123	1063 [9410] 114	1294 [11450] 104		131
		68 [18]		75 [661] 146	305 [2701] 144	555 [4908] 143	764 [6765] 141	1021 [9033] 133	1267 [11214] 124		147
		76 [20]			281 [2489] 163	507 [4490] 162	745 [6597] 156	985 [8719] 150	1236 [10940] 141		164
		83 [22]			227 [2011] 179	473 [4189] 178	714 [6322] 176	948 [8391] 168	1182 [10462] 162		180
		91 [24]			193 [1705] 194	432 [3827] 192	687 [6079] 191	915 [8093] 186			196
		95 [25]				423 [3743] 204	651 [5759] 201	896 [7928] 191			205
		114 [30]				321 [2840] 244	538 [4761] 242	784 [6938] 238			245

Overall Efficiency - 70 - 100%  40 - 69%  0 - 39%

Theoretical Torque - Nm [lb-in]

39.4 [1.553]	127 [1127]	255 [2253]	509 [4506]	764 [6760]	1018 [9013]	1273 [11266]	1528 [13519]
--------------	------------	------------	------------	------------	-------------	--------------	--------------

mm [in]

Displacement tested at 54°C [129°F] with an oil viscosity of 46cSt [213 SUS]

► Performance data is typical. Performance of production units varies slightly from one motor to another. See page 6 for additional information on product testing.

**DISPLACEMENT PERFORMANCE**

		Pressure - bar [psi]					Max. Cont.	Max. Inter.
<b>540</b>		17 [250]	35 [500]	69 [1000]	104 [1500]	138 [2000]	173 [2500]	
536 cm <sup>3</sup> [32.7 in <sup>3</sup> ] / rev								
		Torque - Nm [lb-in]		Speed rpm		Intermittent Ratings - 10% of Operation		
Flow - lpm [gpm]	2 [0.5]	108 [953] 3	215 [1900] 2					4
	4 [1]	107 [946] 6	225 [1995] 6	476 [4212] 5	710 [6284] 5	920 [8138] 3		8
	8 [2]	113 [998] 13	241 [2133] 12	498 [4403] 11	748 [6620] 11	980 [8674] 9	1220 [10798] 8	15
	15 [4]	115 [1014] 28	242 [2137] 27	508 [4491] 26	779 [6893] 25	1038 [9188] 24	1266 [11201] 20	29
	23 [6]	102 [902] 42	234 [2067] 42	505 [4465] 40	771 [6821] 38	1019 [9022] 36	1274 [11275] 32	43
	30 [8]	89 [792] 56	222 [1962] 56	494 [4373] 55	764 [6759] 52	1020 [9029] 48	1280 [11325] 43	57
	38 [10]	71 [630] 70	201 [1782] 70	477 [4224] 68	750 [6639] 66	1016 [8994] 62	1277 [11299] 57	71
	45 [12]	47 [417] 84	188 [1661] 84	455 [4027] 84	729 [6455] 81	1001 [8858] 76	1288 [11394] 69	85
	53 [14]		158 [1397] 98	430 [3803] 97	702 [6214] 96	995 [8803] 89	1264 [11184] 82	99
	61 [16]		132 [1170] 113	403 [3564] 112	670 [5930] 110	944 [8353] 106	1240 [10970] 98	114
	68 [18]		97 [856] 127	366 [3236] 127	640 [5664] 126	935 [8276] 120	1193 [10557] 113	128
	76 [20]		63 [554] 141	335 [2962] 140	604 [5345] 139	878 [7767] 135	1156 [10228] 129	142
	83 [22]			303 [2680] 155	562 [4972] 153	838 [7420] 152	1115 [9868] 145	156
	91 [24]			242 [2141] 169	522 [4622] 167	813 [7194] 164	1075 [9517] 161	170
	95 [25]			226 [1998] 176	490 [4338] 175	772 [6832] 174	1075 [9514] 165	177
114 [30]			98 [864] 211	380 [3365] 210	659 [5834] 209		212	

Overall Efficiency - 70 - 100%  40 - 69%  0 - 39%

**Rotor Width**

45.5 [1.791]  
mm [in]

Theoretical Torque - Nm [lb-in]					
147 [1302]	294 [2604]	588 [5207]	883 [7811]	1177 [10414]	1471 [13018]

Displacement tested at 54°C [129°F] with an oil viscosity of 46cSt [213 SUS]

Pressure - bar [psi] Max. Cont. Max. Inter.

**750**

748 cm<sup>3</sup> [45.6 in<sup>3</sup>] / rev

		Pressure - bar [psi]					Max. Cont.	Max. Inter.
<b>750</b>		17 [250]	35 [500]	69 [1000]	104 [1500]	138 [2000]		
748 cm <sup>3</sup> [45.6 in <sup>3</sup> ] / rev								
		Torque - Nm [lb-in]		Speed rpm		Intermittent Ratings - 10% of Operation		
Flow - lpm [gpm]	2 [0.5]	126 [1118] 1	277 [2450] 1					3
	4 [1]	156 [1378] 4	287 [2537] 3	627 [5552] 3	922 [8155] 2			6
	8 [2]	153 [1357] 9	322 [2853] 9	664 [5873] 8	986 [8722] 7	1308 [11579] 6		11
	15 [4]	148 [1312] 20	327 [2898] 19	686 [6071] 18	1027 [9085] 17	1374 [12161] 16		21
	23 [6]	139 [1230] 30	323 [2860] 29	691 [6113] 28	1040 [9200] 27	1393 [12328] 25		31
	30 [8]	123 [1085] 40	306 [2712] 40	681 [6026] 39	1040 [9207] 36	1380 [12211] 34		41
	38 [10]	99 [874] 50	291 [2571] 49	666 [5897] 48	1035 [9162] 47	1399 [12382] 45		51
	45 [12]	75 [664] 60	274 [2423] 59	643 [5688] 58	1018 [9012] 57	1392 [12318] 55		61
	53 [14]	46 [408] 70	239 [2113] 70	616 [5451] 69	996 [8814] 68	1372 [12146] 64		71
	61 [16]		190 [1682] 81	575 [5089] 80	958 [8479] 78	1327 [11742] 76		82
	68 [18]		150 [1325] 91	535 [4738] 90	921 [8150] 88	1299 [11494] 86		92
	76 [20]		107 [949] 101	486 [4298] 100	878 [7771] 100	1253 [11090] 97		102
	83 [22]			449 [3978] 111	822 [7273] 110	1198 [10598] 108		112
	91 [24]			384 [3401] 121	761 [6736] 120	1143 [10117] 117		122
	95 [25]			369 [3268] 126	737 [6523] 125	1111 [9830] 124		127
114 [30]			116 [1025] 151	494 [4374] 149			152	

Overall Efficiency - 70 - 100%  40 - 69%  0 - 39%

**Rotor Width**

63.5 [2.501]  
mm [in]

Theoretical Torque - Nm [lb-in]					
205 [1815]	410 [3631]	821 [7261]	1231 [10892]	1641 [14522]	

Displacement tested at 54°C [129°F] with an oil viscosity of 46cSt [213 SUS]

► Performance data is typical. Performance of production units varies slightly from one motor to another. See page 6 for additional information on product testing.

**HOUSINGS**

► Dimensions shown are without paint. Paint thickness can be up to 0.13 [.005].

**4-HOLE, MAGNETO MOUNT**

**A2** End Ports    **A8** Side Ports

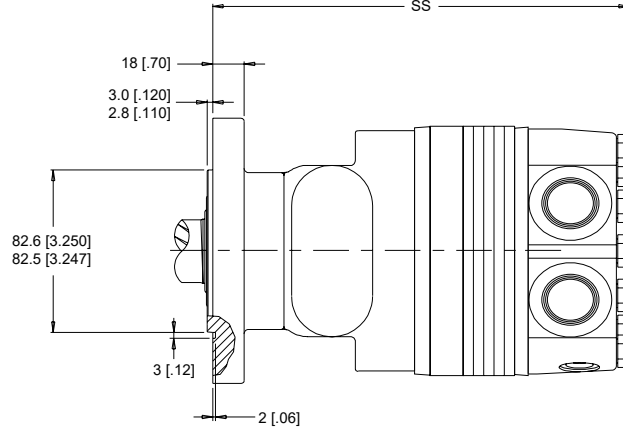
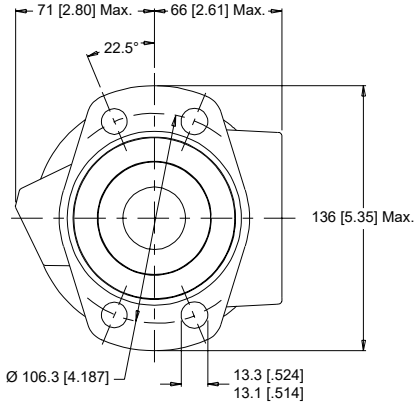

**6-HOLE, SAE A MOUNT**

**A4** End Ports    **A9** Side Ports

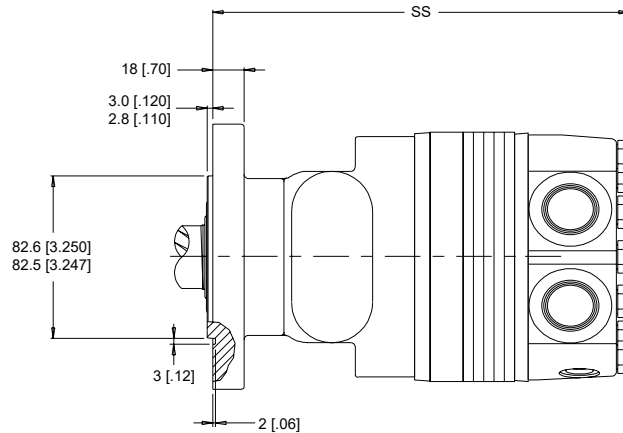
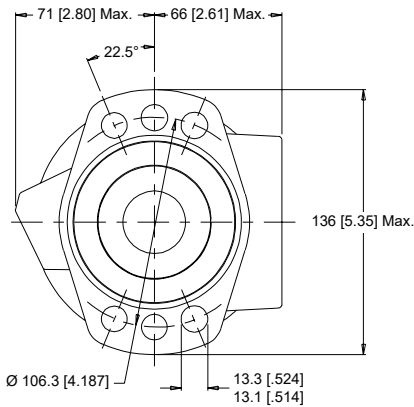

**4-HOLE, WHEEL MOUNT**

**W2** End Ports    **W8** Side Ports

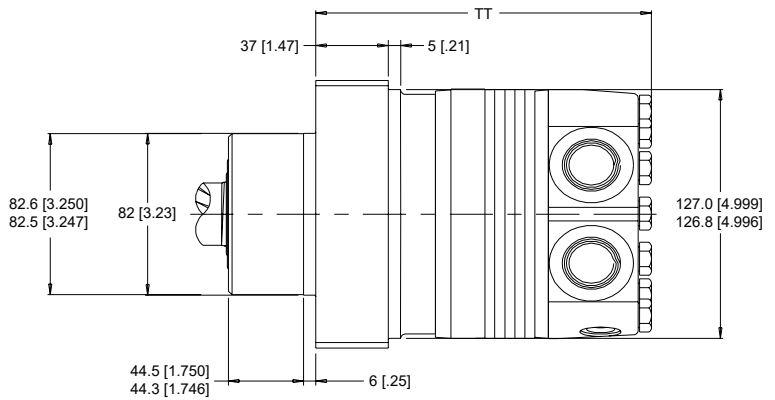
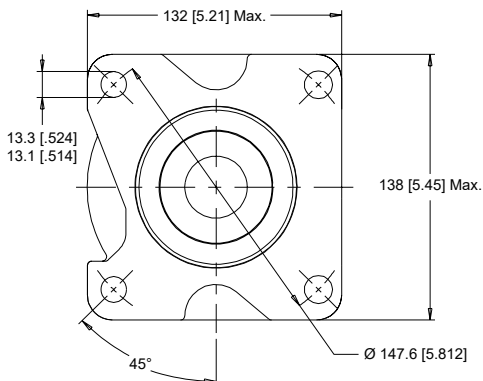

► Dimensions SS & TT are charted on page 22. Porting options listed on pages 23-24.

**TECHNICAL INFORMATION**

**ALLOWABLE SHAFT LOAD / BEARING CURVE**

The bearing curve represents allowable bearing loads based on ISO 281 bearing capacity for an  $L_{10}$  life of 2,000 hours at 100 RPM. Radial loads for speeds other than 100 RPM may be calculated using the multiplication factor table on page 7.

**MAGNETO & SAE A MOUNTS**

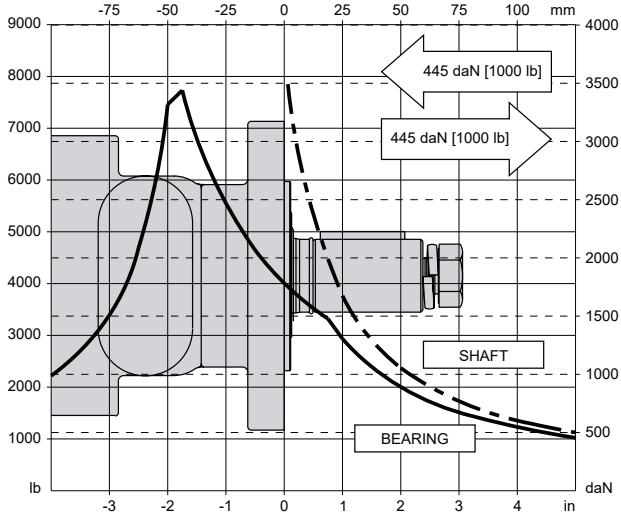

**WHEEL MOUNTS**

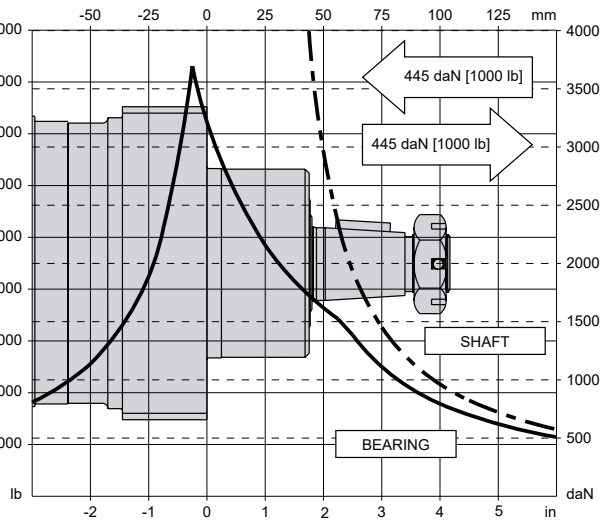

**LENGTH & WEIGHT CHART**

Dimensions SS & TT are the overall motor lengths from the rear of the motor to the mounting flange surface and are referenced on detailed housing drawings listed on page 21.

SS #	Endcovers on pg. 21	Endcovers on pg. 22	Weight
	mm [in]	mm [in]	kg [lb]
200	205 [8.08]	208 [8.19]	15.9 [35.0]
260	210 [8.26]	213 [8.37]	16.3 [36.0]
300	213 [8.39]	216 [8.50]	16.6 [36.6]
350	227 [8.95]	230 [9.06]	17.8 [39.2]
375	219 [8.75]	222 [8.75]	17.1 [37.8]
470	227 [8.95]	230 [9.06]	17.8 [39.2]
540	233 [9.18]	236 [9.29]	18.3 [40.3]
750	251 [9.89]	254 [10.00]	19.7 [43.5]

TT #	Endcovers on pg. 21	Endcovers on pg. 22	Weight
	mm [in]	mm [in]	kg [lb]
200	163 [6.42]	166 [6.53]	13.4 [29.6]
260	168 [6.61]	171 [6.72]	13.9 [30.6]
300	171 [6.74]	174 [6.85]	14.6 [32.2]
350	185 [7.29]	188 [7.40]	15.7 [34.7]
375	177 [6.99]	180 [7.10]	15.2 [33.4]
470	185 [7.29]	188 [7.40]	15.7 [34.7]
540	191 [7.53]	194 [7.64]	16.2 [35.8]
750	209 [8.24]	212 [8.35]	17.7 [39.1]

► All WH series motor weights can vary  $\pm 0.9$  kg [2 lb] depending on model configurations such as housing, shaft, endcover, options etc.

**PORTING**

► Dimensions shown are without paint. Paint thickness can be up to 0.13 [.005].

**END PORTED - OFFSET**

- 1** Main Ports **A, B:** 7/8-14 UNF  
Drain Port **C:** 7/16-20 UNF

STANDARD

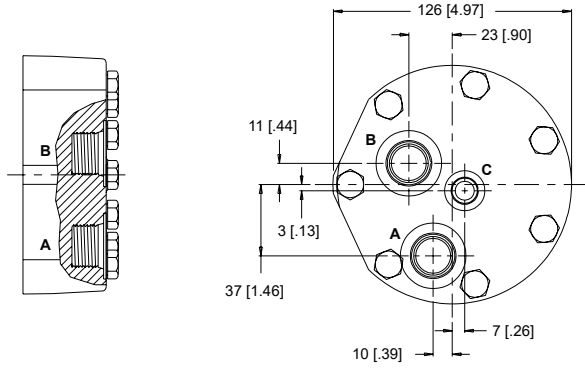

OPTIONAL

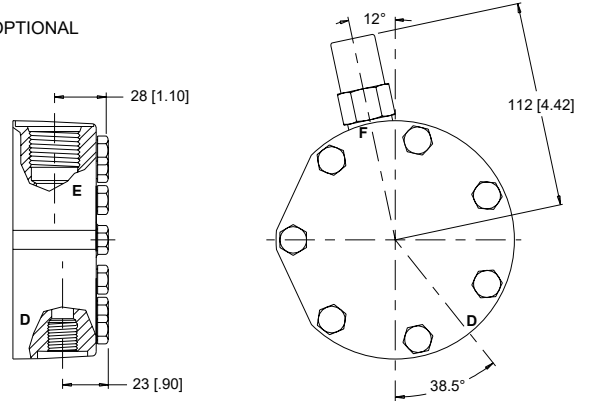

D: Internal Drain E: 10 Series/2-Way Valve Cavity 7/8-14 UNF F: Valve Cartridge Installed

**SIDE PORTED - RADIAL**

- 2** Main Ports **A, B:** G 3/4  
Drain Port **C:** G 1/4

- 5** Main Ports **A, B:** 1 1/16-20 UN  
Drain Port **C:** 7/16-20 UNF

STANDARD

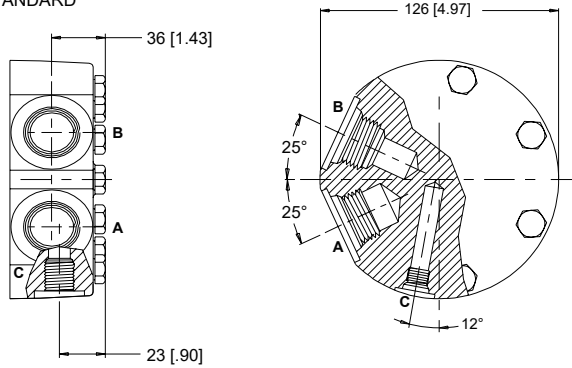

OPTIONAL

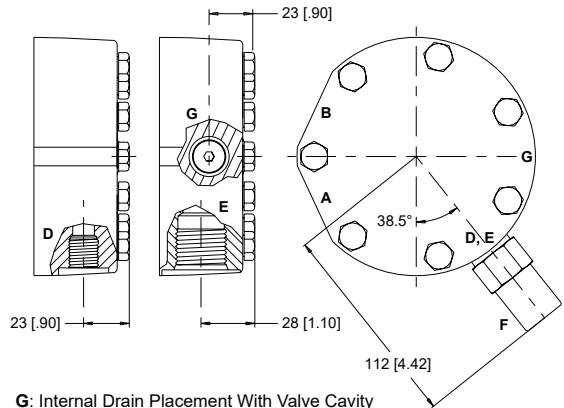

D: Internal Drain E: 10 Series/2-Way Valve Cavity 7/8-14 UNF F: Valve Cartridge Installed G: Internal Drain Placement With Valve Cavity

**WH (600 Series)**  
Medium Duty Hydraulic Motor

**PORTING**

► Dimensions shown are without paint. Paint thickness can be up to 0.13 [.005].

**SIDE PORTED - MANIFOLD ALIGNED**

- 3** Main Ports **A, B:** 11/16" Drilled  
Drain Port **C:** 7/16-20 UNF

**STANDARD**

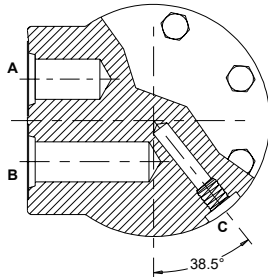
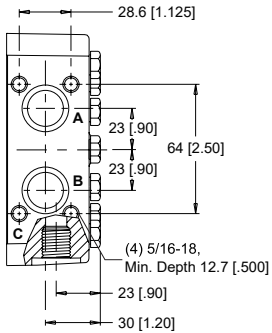

**OPTIONAL**

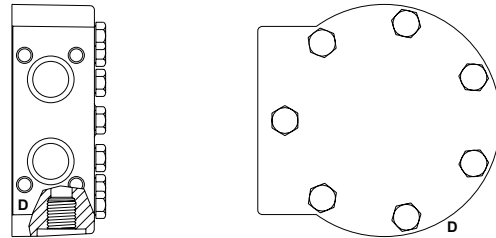

D: Internal Drain

**SIDE PORTED - ALIGNED**

- 6** Main Ports **A, B:** 1 1/16-20 UN  
Drain Port **C:** 7/16-20 UNF

- 7** Main Ports **A, B:** G 3/4  
Drain Port **C:** G 1/4

**STANDARD**

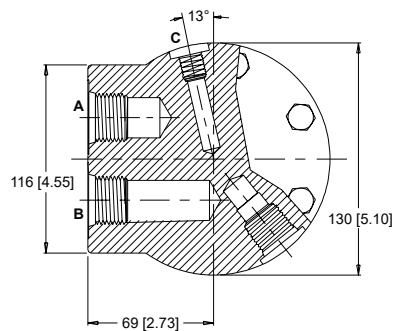
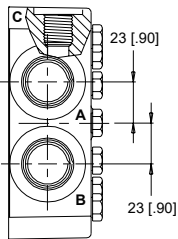

**OPTIONAL**

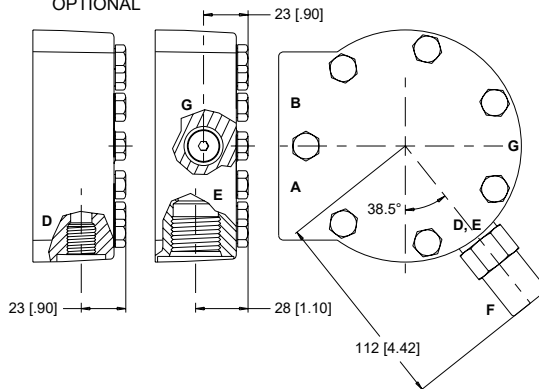

D: Internal Drain E: 10 Series/2-Way Valve Cavity 7/8-14 UNF F: Valve Cartridge Installed G: Internal Drain Placement With Valve Cavity

**SHAFTS**

**02** 1" 6B Spline

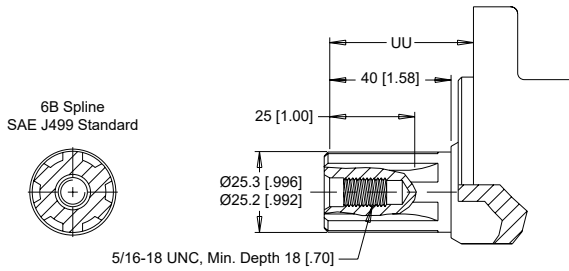

Max. Torque: 678 Nm [6000 lb-in]

**03** 1" 6B Spline Extended

**10** 1" Straight

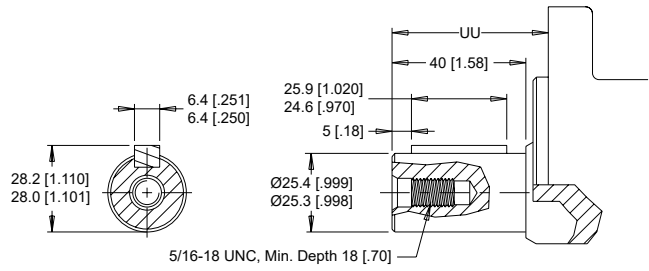

Max. Torque: 655 Nm [5800 lb-in]

**15** 1" Straight Extended

**07** 1-1/4" Straight Extended

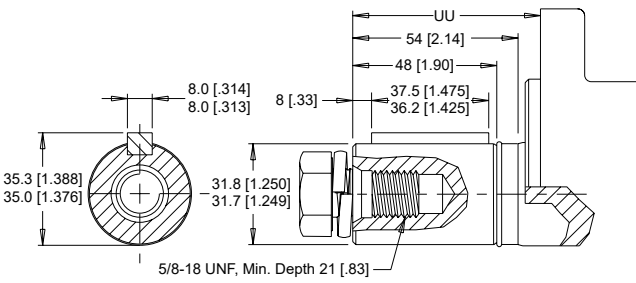

Max. Torque: 1200 Nm [10600 lb-in]

**20** 1-1/4" Straight

**12** 25mm Straight

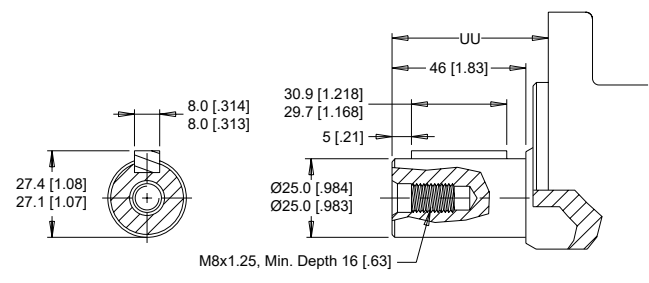

Max. Torque: 678 Nm [6000 lb-in]

**08** 32mm Straight Extended

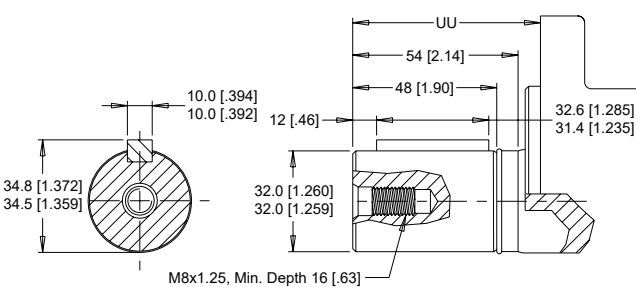

Max. Torque: 1200 Nm [10600 lb-in]

**21** 32mm Straight

**22** 1-1/4" Tapered

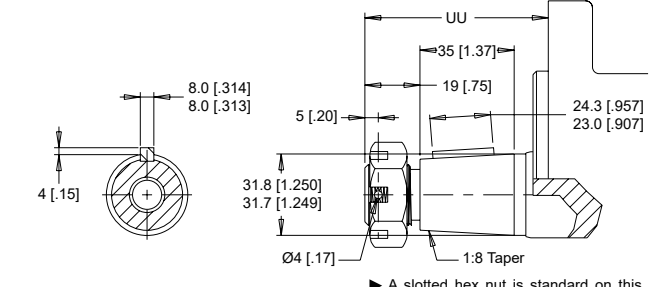

Max. Torque: 1200 Nm [10600 lb-in]

**25** 1-1/4" Tapered Extended

**09** 14 Tooth Spline Extended

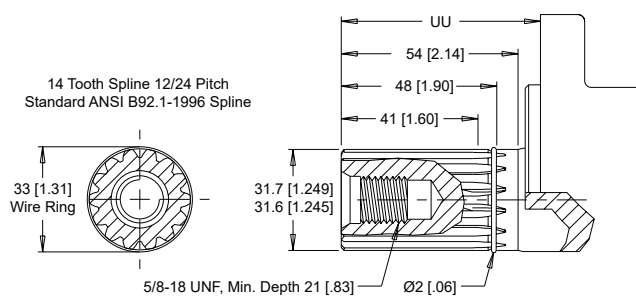

Max. Torque: 1200 Nm [10600 lb-in]

**23** 14 Tooth Spline

**MOUNTING / SHAFT LENGTH CHART**

Dimension UU is the overall distance from the motor mounting surface to the end of the shaft and is referenced on detailed shaft drawings above.

UU	Magneto & A Mounts	Wheel Mounts
#	mm [in]	mm [in]
02	50 [1.97]	91 [3.60]
03	76 [3.01]	118 [4.64]
07	88 [3.45]	129 [5.09]
08	88 [3.45]	129 [5.09]
09	88 [3.45]	129 [5.09]
10	50 [1.97]	91 [3.60]
12	56 [2.21]	98 [3.84]
15	76 [3.01]	118 [4.64]
20	61 [2.41]	103 [4.05]
21	61 [2.41]	103 [4.05]
22	66 [2.58]	107 [4.22]
23	61 [2.41]	103 [4.05]
25	92 [3.62]	134 [5.26]

► Shaft lengths vary ± 0.8 mm [0.030 in.]

**ORDERING INFORMATION**



**1. CHOOSE SERIES DESIGNATION**

**600** Standard Motor

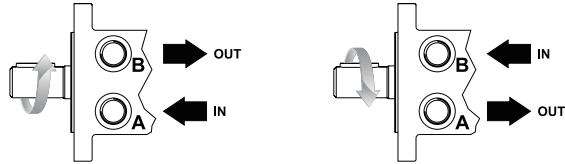

► The 600 series is bi-directional. Reversing the inlet hose will reverse shaft rotation.

**2. SELECT A DISPLACEMENT OPTION**

<b>200</b>	204 cm <sup>3</sup> /rev [12.4 in <sup>3</sup> /rev]	<b>375</b>	375 cm <sup>3</sup> /rev [22.8 in <sup>3</sup> /rev]
<b>260</b>	261 cm <sup>3</sup> /rev [15.9 in <sup>3</sup> /rev]	<b>470</b>	465 cm <sup>3</sup> /rev [28.3 in <sup>3</sup> /rev]
<b>300</b>	300 cm <sup>3</sup> /rev [18.3 in <sup>3</sup> /rev]	<b>540</b>	536 cm <sup>3</sup> /rev [32.7 in <sup>3</sup> /rev]
<b>350</b>	348 cm <sup>3</sup> /rev [21.2 in <sup>3</sup> /rev]	<b>750</b>	748 cm <sup>3</sup> /rev [45.6 in <sup>3</sup> /rev]

**3a. SELECT MOUNT TYPE**

▼ **END MOUNTS**

<b>A2</b>	4-Hole, Magneto Mount
<b>A4</b>	6-Hole, SAE A Mount
<b>W2</b>	4-Hole, Wheel Mount

▼ **SIDE MOUNTS**

<b>A8</b>	4-Hole, Magneto Mount
<b>A9</b>	6-Hole, SAE A Mount
<b>W8</b>	4-Hole, Wheel Mount

**3b. SELECT PORT SIZE**

▼ **END PORT OPTIONS**

<b>1</b>	7/8-14 UNF Offset
----------	-------------------

▼ **SIDE PORT OPTIONS**

<b>2</b>	G 3/4, Radial
<b>3</b>	11/16" Hole, Aligned Manifold
<b>5</b>	1 1/16-20 UN, Radial
<b>6</b>	1 1/16-20 UN, Aligned
<b>7</b>	G 3/4, Radial

► Speed sensor option is not available on wheel mounts.

**4. SELECT A SHAFT OPTION**

<b>02</b>	1" 6B Spline	<b>15</b>	1" Straight Extended
<b>03</b>	1" 6B Spline Extended	<b>20</b>	1-1/4" Straight
<b>07</b>	1-1/4" Straight Extended	<b>21</b>	32mm Straight
<b>08</b>	32mm Straight Extended	<b>22</b>	1-1/4" Tapered
<b>09</b>	14 Tooth Spline Extended	<b>23</b>	14 Tooth Spline
<b>10</b>	1" Straight	<b>25</b>	1-1/4" Tapered Extended
<b>12</b>	25mm Straight		

► For options not listed in the table above, please contact us with your requirements.



**5. SELECT A PAINT OPTION**

<b>A</b>	Black
<b>B</b>	Black, Unpainted Mounting Surface
<b>Z</b>	No Paint

**6. SELECT A VALVE CAVITY / CARTRIDGE OPTION**

<b>A</b>	None	<b>F</b>	121 bar [1750 psi] Relief
<b>B</b>	Valve Cavity Only	<b>G</b>	138 bar [2000 psi] Relief
<b>C</b>	69 bar [1000 psi] Relief	<b>J</b>	173 bar [2500 psi] Relief
<b>D</b>	86 bar [1250 psi] Relief	<b>L</b>	207 bar [3000 psi] Relief
<b>E</b>	104 bar [1500 psi] Relief		

► Valve cavity is not available on port option 3.

**7. SELECT AN ADD-ON OPTION**

<b>A</b>	Standard
<b>B</b>	Lock Nut
<b>C</b>	Solid Hex Nut
<b>W</b>	Speed Sensor, Dual, 4-Pin Male Weatherpack Connector
<b>X</b>	Speed Sensor, Dual, 4-Pin M12 Male Connector
<b>Y</b>	Speed Sensor, Single, 3-Pin Male Weatherpack Connector
<b>Z</b>	Speed Sensor, Single, 4-Pin M12 Male Connector

**8. SELECT A MISCELLANEOUS OPTION**

<b>AA</b>	None
<b>AB</b>	Check Valve Integrated
<b>AC</b>	Freeturning Rotor
<b>AD</b>	Internal Drain & Freeturning Rotor

**HOUSINGS**

► Dimensions shown are without paint. Paint thickness can be up to 0.13 [.005].

**6-HOLE, SAE A MOUNT**

**A4** End Ports

**A9** Side Ports

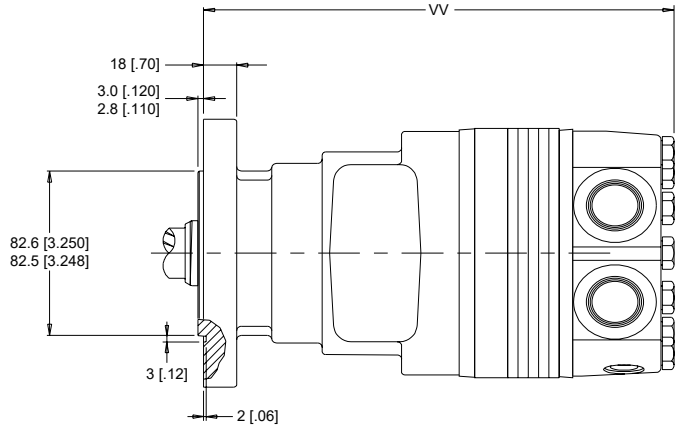
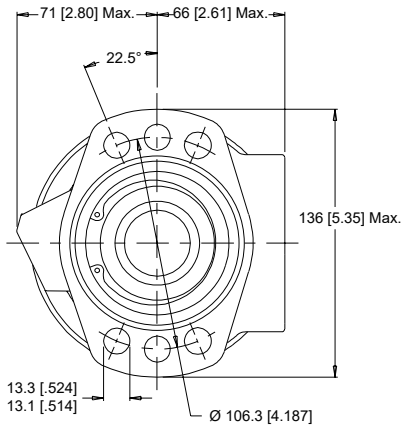

► Porting options listed on pages 28-29.

**TECHNICAL INFORMATION**

**ALLOWABLE SHAFT LOAD / BEARING CURVE**

The bearing curve represents allowable bearing loads based on ISO 281 bearing capacity for an  $L_{10}$  life of 2,000 hours at 100 RPM. Radial loads for speeds other than 100 RPM may be calculated using the multiplication factor table on page 7.

**LENGTH & WEIGHT CHART**

Dimension VV is the overall motor length from the rear of the motor to the mounting flange surface and are referenced on detailed housing drawings listed above.

#	Endcovers on pg. 21	Endcovers on pg. 22	Weight
	mm [in]	mm [in]	
200	231 [9.08]	234 [9.19]	16.1 [35.4]
260	235 [9.27]	238 [9.38]	16.2 [35.6]
300	239 [9.40]	242 [9.51]	16.9 [37.2]
350	253 [9.95]	256 [10.06]	18.0 [39.6]
375	245 [9.65]	248 [9.76]	17.4 [38.3]
470	253 [9.95]	256 [10.06]	18.0 [39.6]
540	259 [10.19]	262 [10.30]	18.5 [40.7]
750	277 [10.90]	280 [11.01]	20.0 [44.0]

**SAE A MOUNTS**

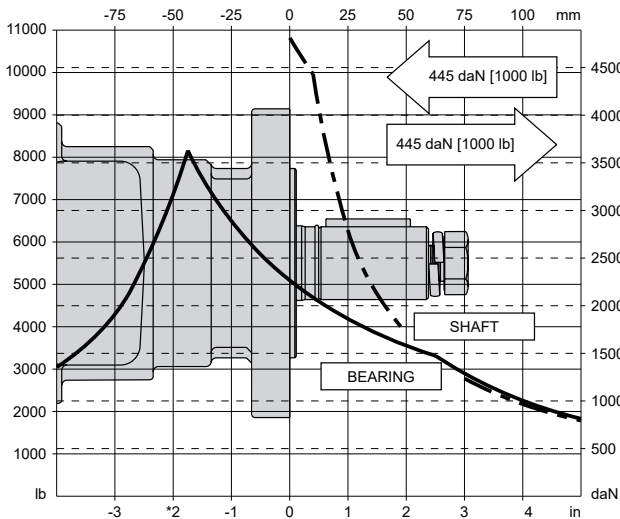

► All WH series motor weights can vary  $\pm 0.9$  kg [2 lb] depending on model configurations such as housing, shaft, endcover, options etc.

**PORTING**

► Dimensions shown are without paint. Paint thickness can be up to 0.13 [.005].

**END PORTED - OFFSET**

- 1** Main Ports **A, B:** 7/8-14 UNF  
Drain Port **C:** 7/16-20 UNF

STANDARD

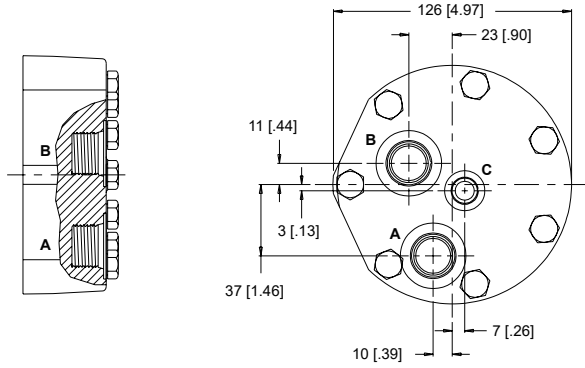

OPTIONAL

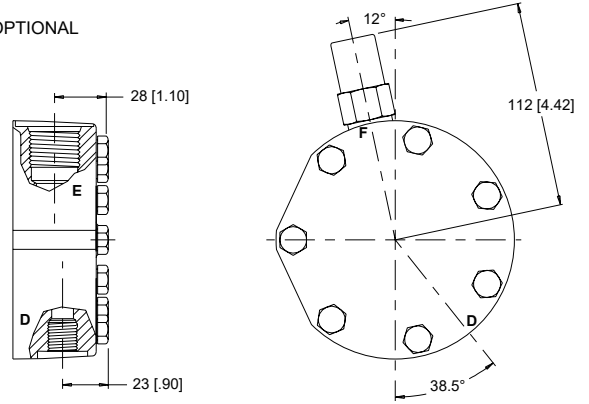

D: Internal Drain E: 10 Series/2-Way Valve Cavity 7/8-14 UNF F: Valve Cartridge Installed

**SIDE PORTED - RADIAL**

- 2** Main Ports **A, B:** G 3/4  
Drain Port **C:** G 1/4

- 5** Main Ports **A, B:** 1 1/16-20 UN  
Drain Port **C:** 7/16-20 UNF

STANDARD

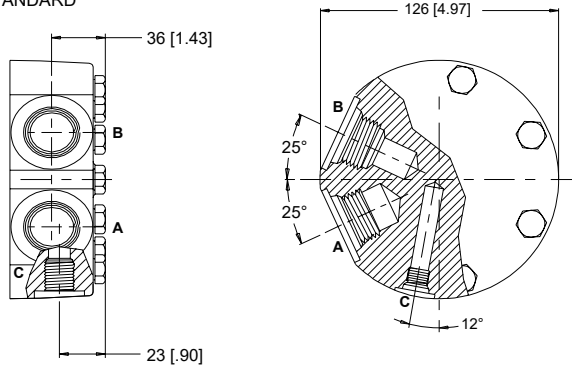

OPTIONAL

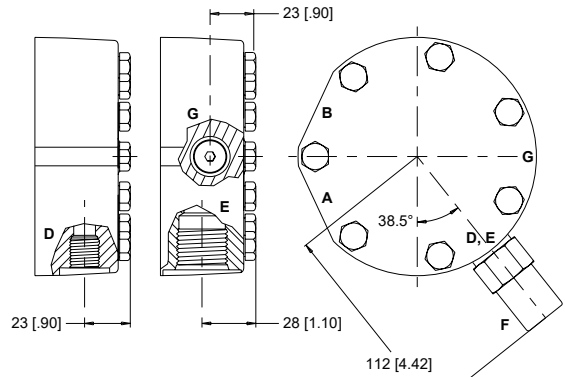

D: Internal Drain E: 10 Series/2-Way Valve Cavity 7/8-14 UNF F: Valve Cartridge Installed G: Internal Drain Placement With Valve Cavity

**PORTING**

► Dimensions shown are without paint. Paint thickness can be up to 0.13 [.005].

**SIDE PORTED - MANIFOLD ALIGNED**

- 3** Main Ports **A, B:** 11/16" Drilled  
Drain Port **C:** 7/16-20 UNF

**STANDARD**

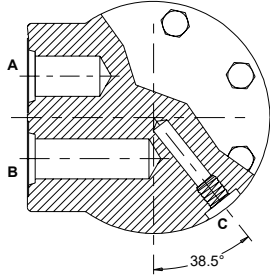
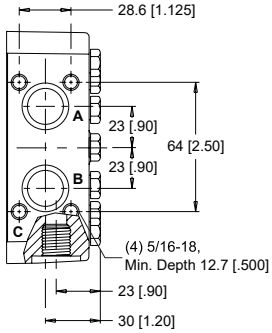

**OPTIONAL**

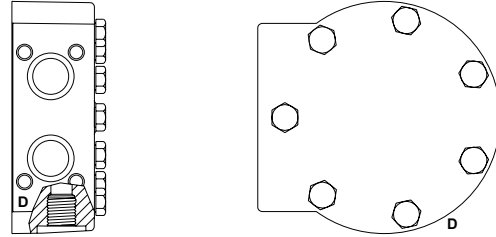

D: Internal Drain

**SIDE PORTED - ALIGNED**

- 6** Main Ports **A, B:** 1 1/16-20 UN  
Drain Port **C:** 7/16-20 UNF

- 7** Main Ports **A, B:** G 3/4  
Drain Port **C:** G 1/4

**STANDARD**

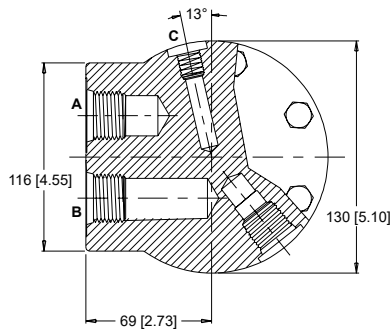
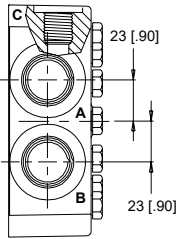

**OPTIONAL**

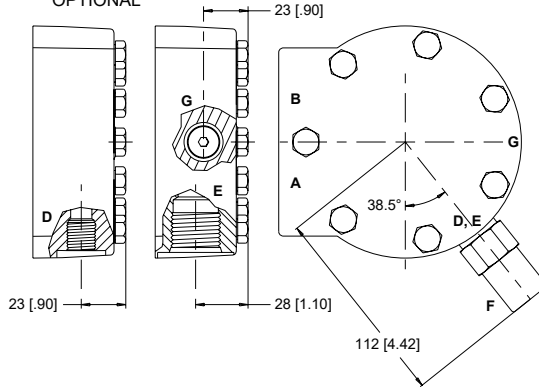

D: Internal Drain E: 10 Series/2-Way Valve Cavity 7/8-14 UNF F: Valve Cartridge Installed G: Internal Drain Placement With Valve Cavity

**SHAFTS**

**03** 1" 6B Spline

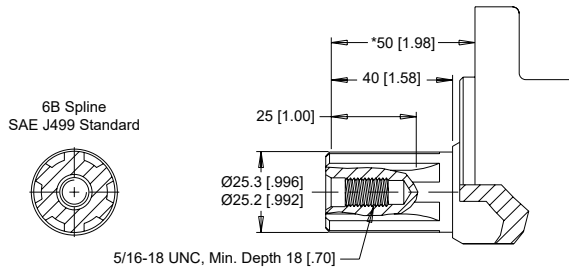

Max. Torque: 678 Nm [6000 lb-in]

**07** 1-1/4" Straight

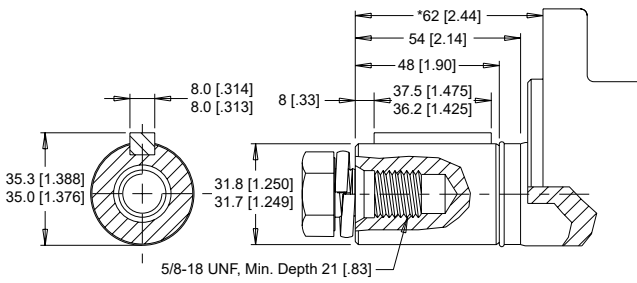

Max. Torque: 1200 Nm [10600 lb-in]

**08** 32mm Straight

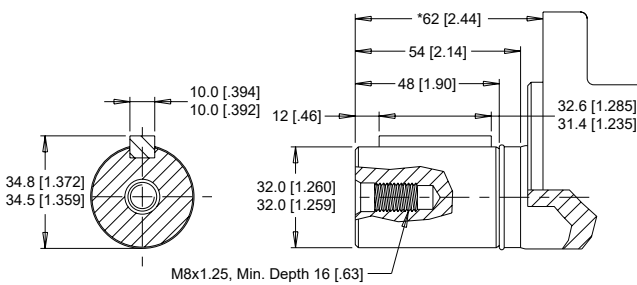

Max. Torque: 1200 Nm [10600 lb-in]

► Shaft lengths vary ± 0.8 mm [0.030 in.]

**09** 14 Tooth Spline

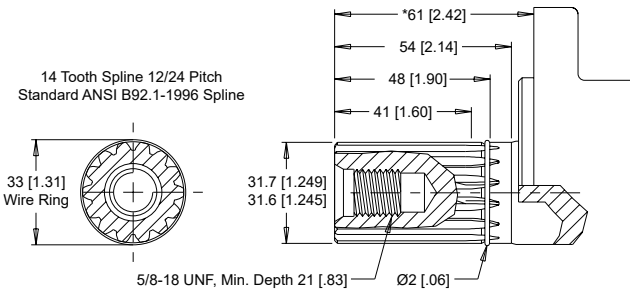

Max. Torque: 1200 Nm [10600 lb-in]

**15** 1" Straight

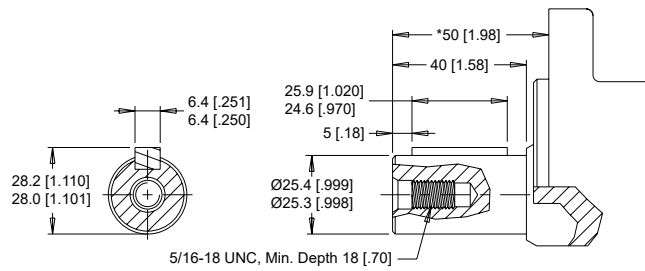

Max. Torque: 655 Nm [5800 lb-in]

**25** 1-1/4" Tapered

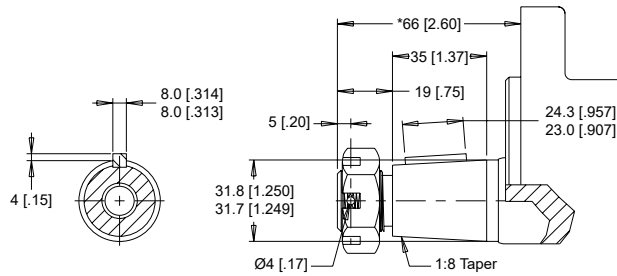

Max. Torque: 1200 Nm [10600 lb-in]

► A slotted hex nut is standard on this shaft. Dimensional details & additional options are listed on page 11.

**ORDERING INFORMATION**

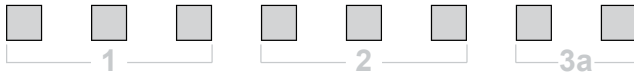

**1. CHOOSE SERIES DESIGNATION**

**620** Hydraulic Motor With Medium Duty Bearing

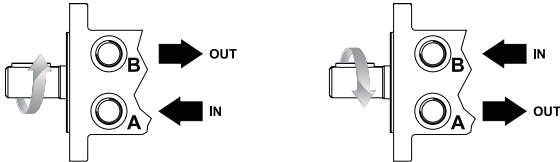

► The 620 series is bi-directional. Reversing the inlet hose will reverse shaft rotation.

**2. SELECT A DISPLACEMENT OPTION**

<b>200</b>	204 cm <sup>3</sup> /rev [12.4 in <sup>3</sup> /rev]	<b>375</b>	375 cm <sup>3</sup> /rev [22.8 in <sup>3</sup> /rev]
<b>260</b>	261 cm <sup>3</sup> /rev [15.9 in <sup>3</sup> /rev]	<b>470</b>	465 cm <sup>3</sup> /rev [28.3 in <sup>3</sup> /rev]
<b>300</b>	300 cm <sup>3</sup> /rev [18.3 in <sup>3</sup> /rev]	<b>540</b>	536 cm <sup>3</sup> /rev [32.7 in <sup>3</sup> /rev]
<b>350</b>	348 cm <sup>3</sup> /rev [21.2 in <sup>3</sup> /rev]	<b>750</b>	748 cm <sup>3</sup> /rev [45.6 in <sup>3</sup> /rev]

**3a. SELECT MOUNT TYPE**

▼ END MOUNTS

**A4** 6-Hole, SAE A Mount

▼ SIDE MOUNTS

**A9** 6-Hole, SAE A Mount

**3b. SELECT PORT SIZE**

▼ END PORT OPTIONS

**1** 7/8-14 UNF Offset

▼ SIDE PORT OPTIONS

- 2** G 3/4, Radial
- 3** 11/16" Hole, Aligned Manifold
- 5** 1 1/16-20 UN, Radial
- 6** 1 1/16-20 UN, Aligned
- 7** G 3/4, Radial

**4. SELECT A SHAFT OPTION**

<b>03</b>	1" 6B Spline	<b>09</b>	14 Tooth Spline
<b>07</b>	1-1/4" Straight	<b>15</b>	1" Straight
<b>08</b>	32mm Straight	<b>25</b>	1-1/4" Tapered

► For options not listed in the table above, please contact us with your requirements.



**5. SELECT A PAINT OPTION**

- A** Black
- B** Black, Unpainted Mounting Surface
- Z** No Paint

**6. SELECT A VALVE CAVITY / CARTRIDGE OPTION**

<b>A</b>	None	<b>F</b>	121 bar [1750 psi] Relief
<b>B</b>	Valve Cavity Only	<b>G</b>	138 bar [2000 psi] Relief
<b>C</b>	69 bar [1000 psi] Relief	<b>J</b>	173 bar [2500 psi] Relief
<b>D</b>	86 bar [1250 psi] Relief	<b>L</b>	207 bar [3000 psi] Relief
<b>E</b>	104 bar [1500 psi] Relief		

► Valve cavity is not available on port option 3.

**7. SELECT AN ADD-ON OPTION**

- A** Standard
- B** Lock Nut
- C** Solid Hex Nut

**8. SELECT A MISCELLANEOUS OPTION**

- AA** None
- AB** Check Valve Integrated
- AC** Freeturning Rotor
- AD** Internal Drain & Freeturning Rotor

**WH (630 Series)**  
Medium Duty Hydraulic Motor



**HOUSINGS**

► Dimensions shown are without paint. Paint thickness can be up to 0.13 [.005].

**4-HOLE, WHEEL MOUNT**

**W2** End Ports    **W8** Side Ports

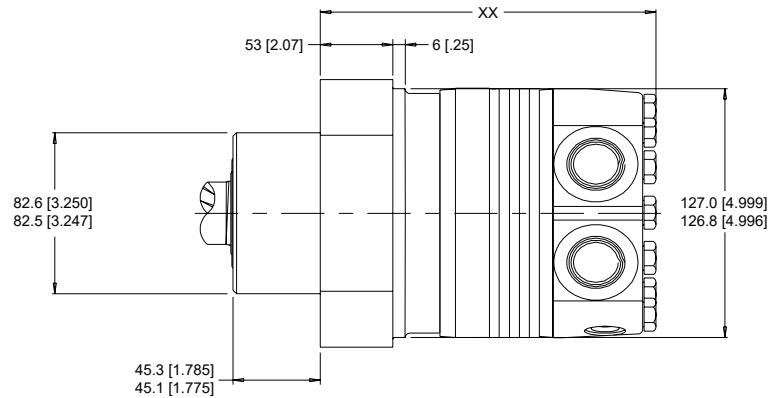
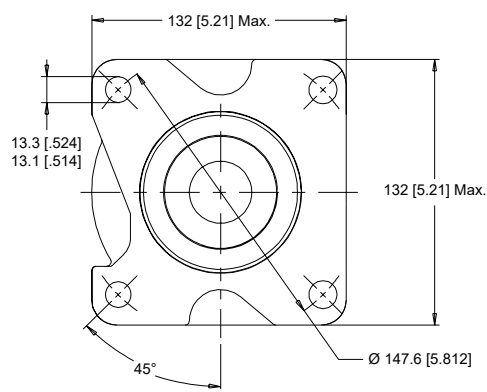

► Porting options listed on pages 33-34.

**TECHNICAL INFORMATION**

**ALLOWABLE SHAFT LOAD / BEARING CURVE**

The bearing curve represents allowable bearing loads based on ISO 281 bearing capacity for an  $L_{10}$  life of 2,000 hours at 100 RPM. Radial loads for speeds other than 100 RPM may be calculated using the multiplication factor table on page 7.

**WHEEL MOUNTS**

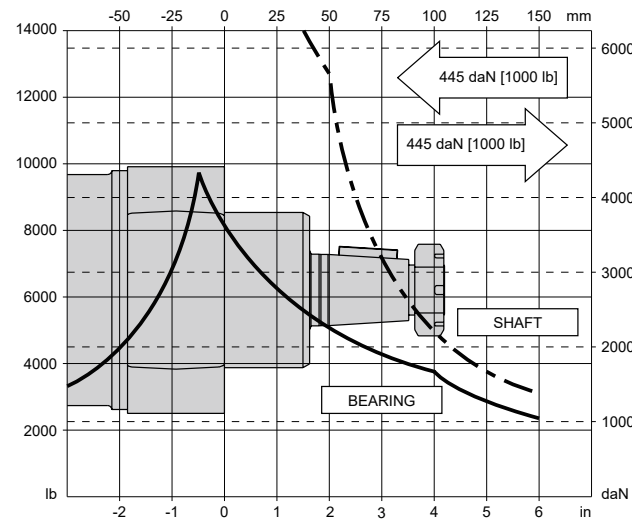

**LENGTH & WEIGHT CHART**

Dimension XX is the overall motor length from the rear of the motor to the mounting flange surface and are referenced on detailed housing drawings listed above.

XX #	Endcovers on pg. 21 mm [in]	Endcovers on pg. 22 mm [in]	Weight kg [lb]
200	199 [7.75]	202 [7.86]	17.5 [38.5]
260	204 [8.04]	207 [8.15]	17.9 [39.5]
300	207 [8.17]	210 [8.28]	18.2 [40.1]
350	221 [8.72]	224 [8.83]	19.3 [42.6]
375	214 [8.42]	217 [8.53]	18.7 [41.2]
470	221 [8.72]	224 [8.83]	19.3 [42.6]
540	227 [8.96]	230 [9.07]	19.8 [43.7]
750	245 [9.67]	248 [9.78]	21.3 [47.0]

► All WH series motor weights can vary  $\pm 0.9$  kg [2 lb] depending on model configurations such as housing, shaft, endcover, options etc.

**PORTING**

► Dimensions shown are without paint. Paint thickness can be up to 0.13 [.005].

**END PORTED - OFFSET**

- 1** Main Ports **A, B:** 7/8-14 UNF  
Drain Port **C:** 7/16-20 UNF

STANDARD

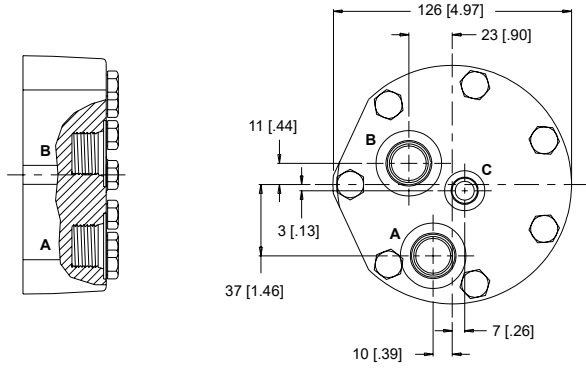

OPTIONAL

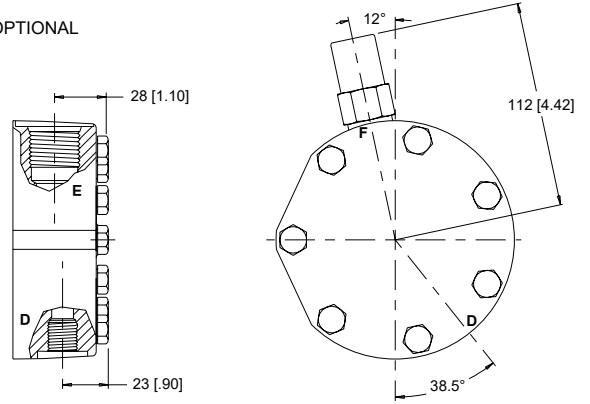

D: Internal Drain E: 10 Series/2-Way Valve Cavity 7/8-14 UNF F: Valve Cartridge Installed

**SIDE PORTED - RADIAL**

- 2** Main Ports **A, B:** G 3/4  
Drain Port **C:** G 1/4

- 5** Main Ports **A, B:** 1 1/16-20 UN  
Drain Port **C:** 7/16-20 UNF

STANDARD

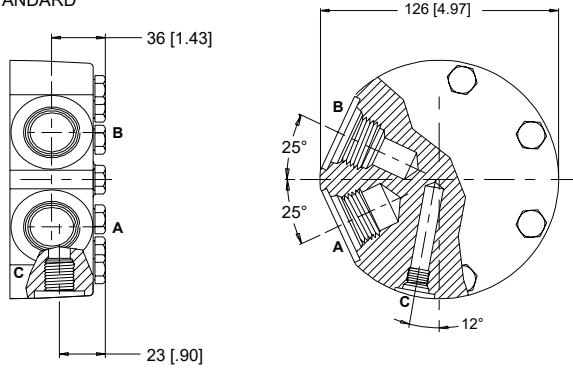

OPTIONAL

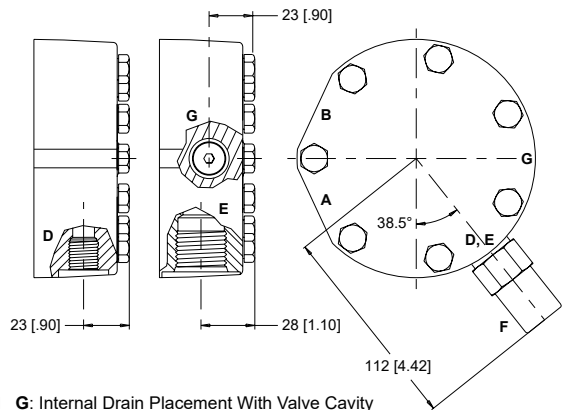

D: Internal Drain E: 10 Series/2-Way Valve Cavity 7/8-14 UNF F: Valve Cartridge Installed G: Internal Drain Placement With Valve Cavity

**WH (630 Series)**  
Medium Duty Hydraulic Motor

**PORTING**

► Dimensions shown are without paint. Paint thickness can be up to 0.13 [.005].

**SIDE PORTED - MANIFOLD ALIGNED**

- 3** Main Ports **A, B:** 11/16" Drilled  
Drain Port **C:** 7/16-20 UNF

**STANDARD**

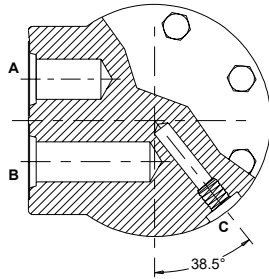
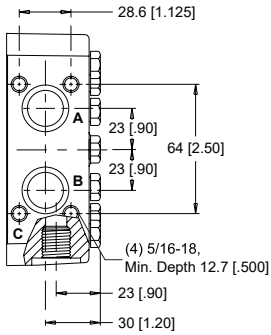

**OPTIONAL**

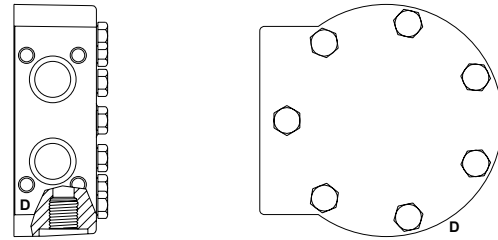

D: Internal Drain

**SIDE PORTED - ALIGNED**

- 6** Main Ports **A, B:** 1 1/16-20 UN  
Drain Port **C:** 7/16-20 UNF

- 7** Main Ports **A, B:** G 3/4  
Drain Port **C:** G 1/4

**STANDARD**

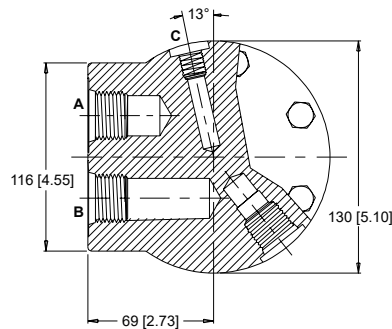
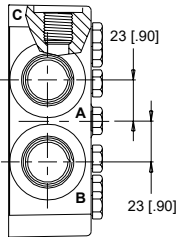

**OPTIONAL**

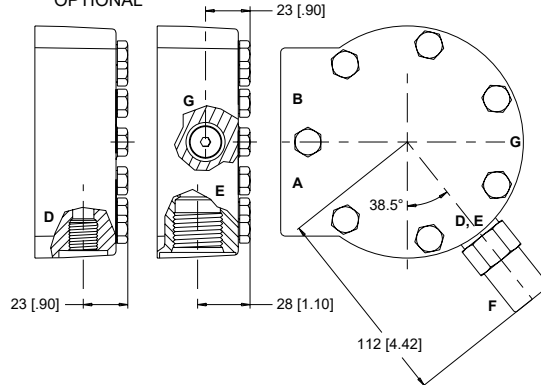

D: Internal Drain E: 10 Series/2-Way Valve Cavity 7/8-14 UNF F: Valve Cartridge Installed G: Internal Drain Placement With Valve Cavity

**SHAFTS**

**28** 35mm Tapered

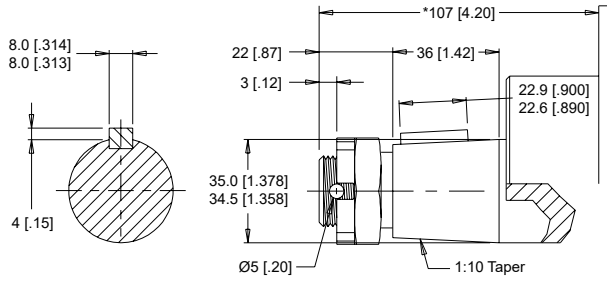

► A slotted hex nut is standard on this shaft. Dimensional details are listed on page 11.

Max. Torque: 1200 Nm [10600 lb-in]

**30** 1-1/2" Straight

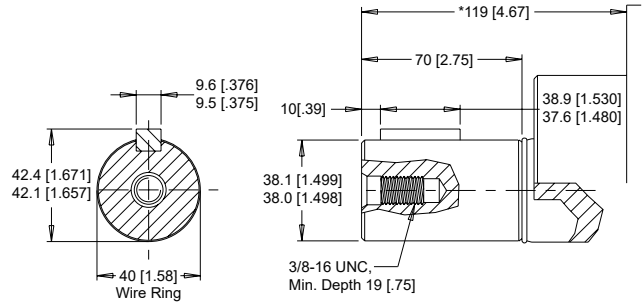

Max. Torque: 1200 Nm [10600 lb-in]

**31** 1-1/2" Tapered

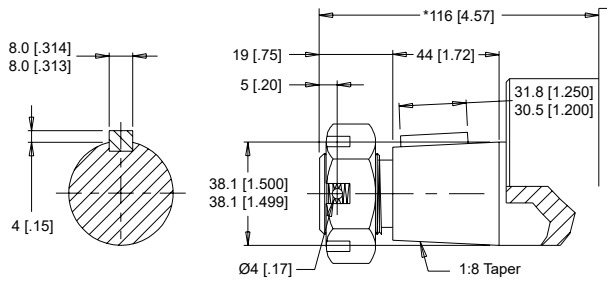

► A slotted hex nut is standard on this shaft. Dimensional details & additional options are listed on page 11.

Max. Torque: 1200 Nm [10600 lb-in]

► Shaft lengths vary  $\pm 0.8$  mm [0.031 in.]

**ORDERING INFORMATION**



**1. CHOOSE SERIES DESIGNATION**

**630** Hydraulic Motor With Heavy Duty Bearing

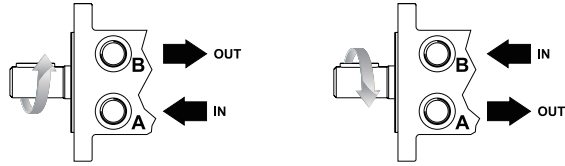

► The 630 series is bi-directional. Reversing the inlet hose will reverse shaft rotation.

**2. SELECT A DISPLACEMENT OPTION**

<b>200</b>	204 cm <sup>3</sup> /rev [12.4 in <sup>3</sup> /rev]	<b>375</b>	375 cm <sup>3</sup> /rev [22.8 in <sup>3</sup> /rev]
<b>260</b>	261 cm <sup>3</sup> /rev [15.9 in <sup>3</sup> /rev]	<b>470</b>	465 cm <sup>3</sup> /rev [28.3 in <sup>3</sup> /rev]
<b>300</b>	300 cm <sup>3</sup> /rev [18.3 in <sup>3</sup> /rev]	<b>540</b>	536 cm <sup>3</sup> /rev [32.7 in <sup>3</sup> /rev]
<b>350</b>	348 cm <sup>3</sup> /rev [21.2 in <sup>3</sup> /rev]	<b>750</b>	748 cm <sup>3</sup> /rev [45.6 in <sup>3</sup> /rev]

**3a. SELECT MOUNT TYPE**

- ▼ **END MOUNTS**
- W2** 4-Hole, Wheel Mount
- ▼ **SIDE MOUNTS**
- W8** 4-Hole, Wheel Mount

**3b. SELECT PORT SIZE**

- ▼ **END PORT OPTIONS**
- 1** 7/8-14 UNF Offset
- ▼ **SIDE PORT OPTIONS**
- 2** G 3/4, Radial
- 3** 11/16" Hole, Aligned Manifold
- 5** 1 1/16-20 UN, Radial
- 6** 1 1/16-20 UN, Aligned
- 7** G 3/4, Radial

**4. SELECT A SHAFT OPTION**

- 28** 35mm Tapered
- 30** 1-1/2" Straight
- 31** 1-1/2" Tapered

► For options not listed in the table above, please contact us with your requirements.



**5. SELECT A PAINT OPTION**

- A** Black
- B** Black, Unpainted Mounting Surface
- Z** No Paint

**6. SELECT A VALVE CAVITY / CARTRIDGE OPTION**

<b>A</b>	None	<b>F</b>	121 bar [1750 psi] Relief
<b>B</b>	Valve Cavity Only	<b>G</b>	138 bar [2000 psi] Relief
<b>C</b>	69 bar [1000 psi] Relief	<b>J</b>	173 bar [2500 psi] Relief
<b>D</b>	86 bar [1250 psi] Relief	<b>L</b>	207 bar [3000 psi] Relief
<b>E</b>	104 bar [1500 psi] Relief		

► Valve cavity is not available on port option 3.

**7. SELECT AN ADD-ON OPTION**

- A** Standard
- B** Lock Nut
- C** Solid Hex Nut

**8. SELECT A MISCELLANEOUS OPTION**

- AA** None
- AB** Check Valve Integrated
- AC** Freeturning Rotor
- AD** Internal Drain & Freeturning Rotor



# ***Impro*** *Fluidtek*

---

## **USA**

400 E. Diehl Road, Suite 500  
Naperville, IL 60563  
USA

Email: [sales.americas@improfluidtek.com](mailto:sales.americas@improfluidtek.com)

## **Luxembourg**

10 Boulevard Royal, 2449  
Luxembourg

Email: [sales.emea@improfluidtek.com](mailto:sales.emea@improfluidtek.com)

## **China**

No.18, Furong Road 5  
Xishan Economy Development Zone  
Wuxi, Jiangsu  
China

Email: [sales.apac@improfluidtek.com](mailto:sales.apac@improfluidtek.com)

---