

Impro
Fluidtek

Technical Information

Orbital Motors Type WT

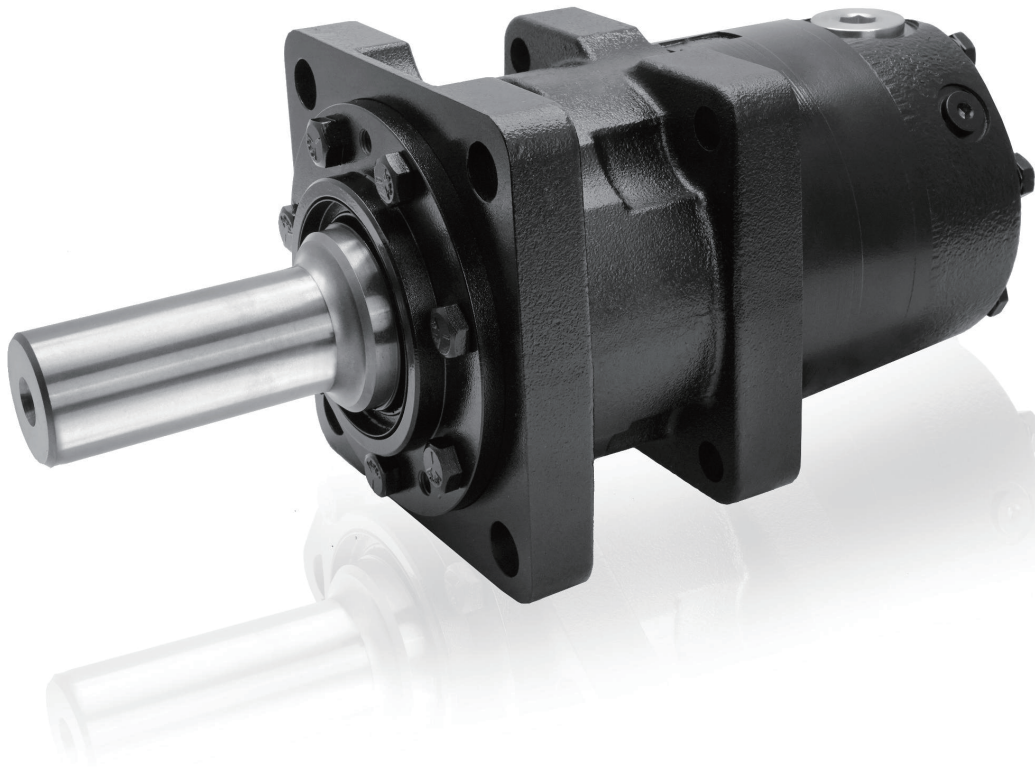

www.Improfluidtek.com

TABLE OF CONTENTS

TECHNICAL INFORMATION

Operating Recommendations.....	4-5
Motor Connections.....	6
Product Testing (Understanding the Performance Charts).....	7
Allowable Bearing & Shaft Loads.....	8
Vehicle Drive Calculations.....	9-11
Induced Side Loading	12
Hydraulic Equations	12
Shaft Nut Dimensions & Torque Specifications	13

OPTIONAL MOTOR FEATURES

Speed Sensor Options	14-15
Freeturning Rotor Option.....	15
Internal Drain	16
Hydraulic Declutch.....	16
Valve Cavity Option.....	17
Slinger Seal Option	17

HYDRAULIC MOTOR FOR HEAVY DUTY APPLICATION

WT Product Line Introduction.....	18
WT Displacement Performance Charts	19-27
700 Series Housings.....	28
700 Series Permissible Shaft Side / Axial Load & Thrust Load.....	28
700 Porting Options.....	29-30
700 Series Shafts	31-32
700 Series Ordering Information.....	33
701 Series Housings	34
701 Series Permissible Shaft Side / Axial Load & Thrust Load.....	34
701 Porting Options.....	35-36
701 Series Shafts	37
701 Series Ordering Information	38

OPERATING RECOMMENDATIONS

OIL TYPE

Hydraulic oils with anti-wear, anti-foam and demulsifiers are recommended for systems incorporating Impro Fluidtek motors. Straight oils can be used but may require VI (viscosity index) improvers depending on the operating temperature range of the system. Other water based and environmentally friendly oils may be used, but service life of the motor and other components in the system may be significantly shortened. Before using any type of fluid, consult the fluid requirements for all components in the system for compatibility. Testing under actual operating conditions is the only way to determine if acceptable service life will be achieved.

FLUID VISCOSITY & FILTRATION

Fluids with a viscosity between 20 - 43 cSt [100 - 200S.U.S.] at operating temperature is recommended. Fluid temperature should also be maintained below 85°C [180°F]. It is also suggested that the type of pump and its operating specifications be taken into account when choosing a fluid for the system. Fluids with high viscosity can cause cavitation at the inlet side of the pump. Systems that operate over a wide range of temperatures may require viscosity improvers to provide acceptable fluid performance.

Impro Fluidtek recommends maintaining an oil cleanliness level of ISO 17-14 or better.

INSTALLATION & START-UP

When installing an Impro Fluidtek motor it is important that the mounting flange of the motor makes full contact with the mounting surface of the application. Mounting hardware of the appropriate grade and size must be used. Hubs, pulleys, sprockets and couplings must be properly aligned to avoid inducing excessive thrust or radial loads. Although the output device must fit the shaft snug, a hammer should never be used to install any type of output device onto the shaft. The port plugs should only be removed from the motor when the system connections are ready to be made. To avoid contamination, remove all matter from around the ports of the motor and the threads of the fittings. Once all system connections are made, it is recommended that the motor be run-in for 15-30 minutes at no load and half speed to remove air from the hydraulic system.

MOTOR PROTECTION

Over-pressurization of a motor is one of the primary causes of motor failure. To prevent these situations, it is necessary to provide adequate relief protection for a motor based on the pressure ratings for that particular model. For systems that may experience overrunning conditions, special precautions must be taken. In an overrunning condition, the motor functions as a pump and attempts to convert kinetic energy into hydraulic energy. Unless the system is properly configured for this condition, damage to the motor or system can occur. To protect against this condition a counterbalance valve or relief cartridge must be incorporated into the circuit to reduce the risk of over-pressurization. If a relief cartridge is used, it must be installed upline of the motor, if not in the motor, to relieve the pressure created by the over-running motor. To provide proper motor protection for an over-running load application, the pressure setting of the pressure relief valve must not exceed the intermittent rating of the motor.

HYDRAULIC MOTOR SAFETY PRECAUTION

A hydraulic motor must not be used to hold a suspended load. Due to the necessary internal tolerances, all hydraulic motors will experience some degree of creep when a load induced torque is applied to a motor at rest. All applications that require a load to be held must use some form of mechanical brake designed for that purpose.

MOTOR/BRAKE PRECAUTION

Caution! - Impro Fluidtek motor/brakes are intended to operate as static or parking brakes. System circuitry must be designed to bring the load to a stop before applying the brake.

Caution! - Because it is possible for some large displacement motors to overpower the brake, it is critical that the maximum system pressure be limited for these applications. Failure to do so could cause serious injury or death. When choosing a motor/brake for an application, consult the performance chart for the series and displacement chosen for the application to verify that the maximum operating pressure of the system will not allow the motor to produce more torque than the maximum rating of the brake. Also, it is vital that the system relief be set low enough to insure that the motor is not able to overpower the brake.

To ensure proper operation of the brake, a separate case drain back to tank must be used. Use of the internal drain option is not recommended due to the possibility of return line pressure spikes. A simple schematic of a system utilizing a motor/brake is shown on page 6. Although maximum brake release pressure may be used for an application, a 34 bar [500 psi] pressure reducing valve is recommended to promote maximum life for the brake release piston seals. However, if a pressure reducing valve is used in a system which has case drain back pressure, the pressure reducing valve should be set to 34 bar [500 psi] over the expected case pressure to ensure full brake release. To achieve proper brake release operation, it is necessary to bleed out any trapped air and fill brake release cavity and hoses before all connections are tightened. To facilitate this operation, all motor/brakes feature two release ports. One or both of these ports may be used to release the brake in the unit. Motor/brakes should be configured so that the release ports are near the top of the unit in the installed position.

OPERATING RECOMMENDATIONS & MOTOR CONNECTIONS

Once all system connections are made, one release port must be opened to atmosphere and the brake release line carefully charged with fluid until all air is removed from the line and motor/brake release cavity. When this has been accomplished the port plug or secondary release line must be reinstalled. In the event of a pump or battery failure, an external pressure source may be connected to the brake release port to release the brake, allowing the machine to be moved.

► NOTE: It is vital that all operating recommendations be followed. Failure to do so could result in injury or death.

MOTOR CIRCUITS

There are two common types of circuits used for connecting multiple numbers of motors – series connection and parallel connection.

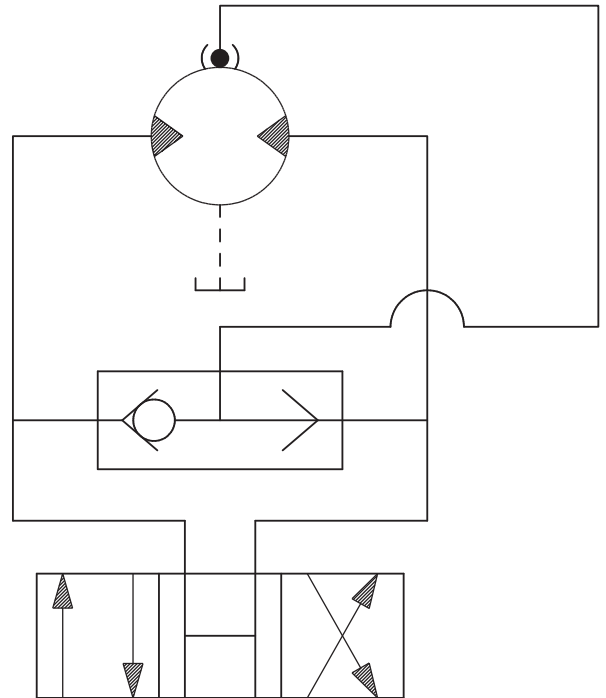

TYPICAL MOTOR/BRAKE SCHEMATIC

SERIES CONNECTION

When motors are connected in series, the outlet of one motor is connected to the inlet of the next motor. This allows the full pump flow to go through each motor and provide maximum speed. Pressure and torque are distributed between the motors based on the load each motor is subjected to. The maximum system pressure must be no greater than the maximum inlet pressure of the first motor. The allowable back pressure rating for a motor must also be considered. In some series circuits the motors must have an external case drain connected. A series connection is desirable when it is important for all the motors to run the same speed such as on a long line conveyor.

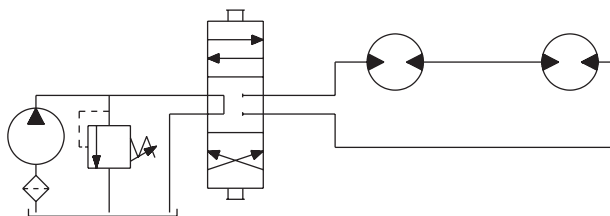

SERIES CIRCUIT

PARALLEL CONNECTION

In a parallel connection all of the motor inlets are connected. This makes the maximum system pressure available to each motor allowing each motor to produce full torque at that pressure. The pump flow is split between the individual motors according to their loads and displacements. If one motor has no load, the oil will take the path of least resistance and all the flow will go to that one motor. The others will not turn. If this condition can occur, a flow divider is recommended to distribute the oil and act as a differential.

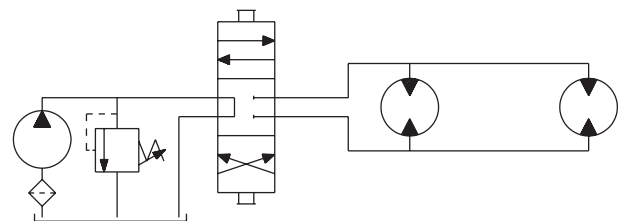

PARALLEL CIRCUIT

► NOTE: The motor circuits shown above are for illustration purposes only. Components and circuitry for actual applications may vary greatly and should be chosen based on the application.

PRODUCT TESTING

Performance testing is the critical measure of a motor's ability to convert flow and pressure into speed and torque. All product testing is conducted using an Impro Fluidtek state of the art test facility. This facility utilizes fully automated test equipment and custom designed software to provide accurate, reliable test data. Test routines are standardized, including test stand calibration and stabilization of fluid temperature and viscosity, to provide consistent data. The example below provides an explanation of the values pertaining to each heading on the performance chart.

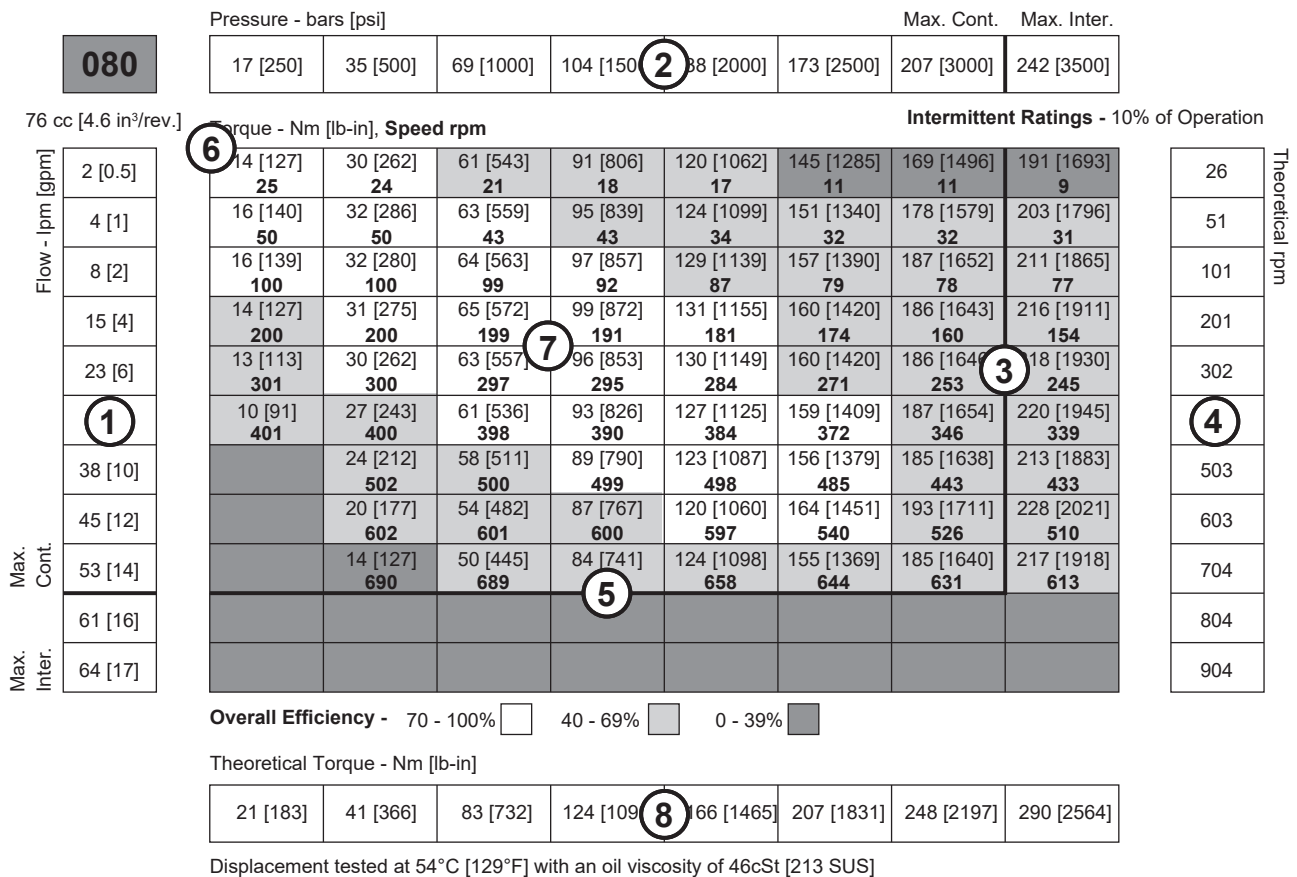

1. Flow represents the amount of fluid passing through the motor during each minute of the test.
2. Pressure refers to the measured pressure differential between the inlet and return ports of the motor during the test.
3. The maximum continuous pressure rating and maximum intermittent pressure rating of the motor are separated by the dark lines on the chart.
4. Theoretical RPM represents the RPM that the motor would produce if it were 100% volumetrically efficient. Measured RPM divided by the theoretical RPM give the actual volumetric efficiency of the motor.
5. The maximum continuous flow rating and maximum intermittent flow rating of the motor are separated by the dark line on the chart.
6. Performance numbers represent the actual torque and speed generated by the motor based on the corresponding input pressure and flow. The numbers on the top row indicate torque as measured in Nm [lb-in], while the bottom number represents the speed of the output shaft.
7. Areas within the white shading represent maximum motor efficiencies.
8. Theoretical Torque represents the torque that the motor would produce if it were 100% mechanically efficient. Actual torque divided by the theoretical torque gives the actual mechanical efficiency of the motor.

ALLOWABLE BEARING & SHAFT LOADING

This catalog provides curves showing allowable radial loads at points along the longitudinal axis of the motor. They are dimensioned from the mounting flange. Two capacity curves for the shaft and bearings are shown. A vertical line through the centerline of the load drawn to intersect the x-axis intersects the curves at the load capacity of the shaft and of the bearing.

In the example below the maximum radial load bearing rating is between the internal roller bearings illustrated with a solid line. The allowable shaft rating is shown with a dotted line.

The bearing curves for each model are based on laboratory analysis and testing results constructed at Impro Fluidtek. The shaft loading is based on a 3:1 safety factor and 330 Kpsi tensile strength. The allowable load is the lower of the curves at a given point. For instance, one inch in front of the mounting flange the bearing capacity is lower than the shaft capacity. In this case, the bearing is the limiting load. The motor user needs to determine which series of motor to use based on their application knowledge.

ISO 281 RATINGS VS. MANUFACTURERS RATINGS

Published bearing curves can come from more than one type of analysis. The ISO 281 bearing rating is an international standard for the dynamic load rating of roller bearings. The rating is for a set load at a speed of 33 1/3 RPM for 500 hours (1 million revolutions). The standard was established to allow consistent comparisons of similar bearings between manufacturers. The ISO 281 bearing ratings are based solely on the physical characteristics of the bearings, removing any manufacturers specific safety factors or empirical data that influences the ratings.

Manufacturers' ratings are adjusted by diverse and systematic laboratory investigations, checked constantly with feedback from practical experience. Factors taken into account that affect bearing life are material, lubrication, cleanliness of the lubrication, speed, temperature, magnitude of the load and the bearing type.

The operating life of a bearing is the actual life achieved by the bearing and can be significantly different from the calculated life. Comparison with similar applications is the most accurate method for bearing life estimations.

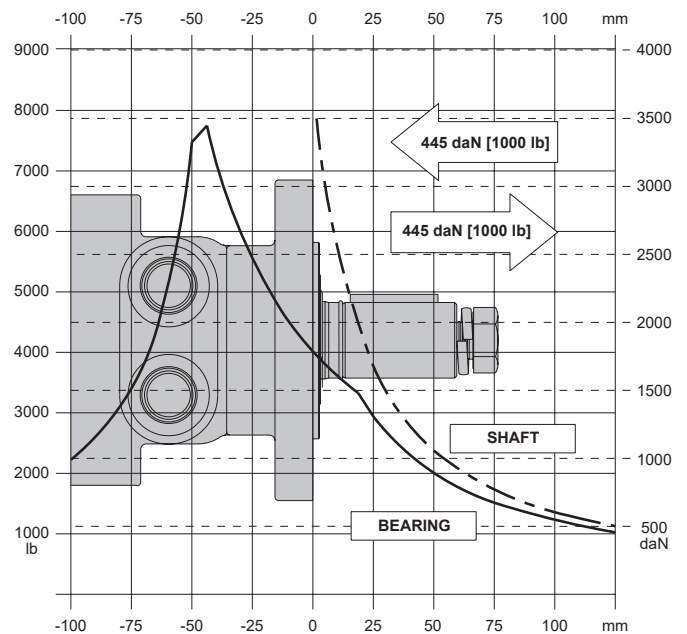

EXAMPLE LOAD RATING FOR MECHANICALLY RETAINED NEEDLE ROLLER BEARINGS

$$\text{Bearing Life } L_{10} = (C/P)^p [10^6 \text{ revolutions}]$$

$$L_{10} = \text{nominal rating life}$$

$$C = \text{dynamic load rating}$$

$$P = \text{equivalent dynamic load}$$

$$\text{Life Exponent } p = 10/3 \text{ for needle bearings}$$

BEARING LOAD MULTIPLICATION FACTOR TABLE			
RPM	FACTOR	RPM	FACTOR
50	1.23	500	0.62
100	1.00	600	0.58
200	0.81	700	0.56
300	0.72	800	0.50
400	0.66		

VEHICLE DRIVE CALCULATIONS

When selecting a wheel drive motor for a mobile vehicle, a number of factors concerning the vehicle must be taken into consideration to determine the required maximum motor RPM, the maximum torque required and the maximum load each motor must support. The following sections contain the necessary equations to determine this criteria. An example is provided to illustrate the process.

Sample application (vehicle design criteria)

Vehicle description.....	4 wheel vehicle	Vehicle drive.....	2 wheel drive
GVW	1,500 lbs.	Weight over each drive wheel	425 lbs.
Rolling radius of tires	16 in.	Desired acceleration	0-5 mph in 10 sec.
Top speed.....	5 mph	Gradability.....	20%
Worst working surface.....	poor asphalt		

To determine maximum motor speed

$$RPM = \frac{2.65 \times KPH \times G}{r_m} \quad RPM = \frac{168 \times MPH \times G}{r_i}$$

Where:

MPH = Max. vehicle speed (miles/hr) KPH = Max. vehicle speed (kilometers/hr) r_i = Rolling radius of tire (inches)
 G = Gear reduction ratio (if none, G = 1) r_m = Rolling radius of tire (meters)

Example $RPM = \frac{168 \times 5 \times 1}{16} = 52.5$

To determine maximum torque requirement of motor

To choose a motor(s) capable of producing enough torque to propel the vehicle, it is necessary to determine the Total Tractive Effort (TE) requirement for the vehicle.

To determine the total tractive effort, the following equation must be used:

TE = RR + GR + FA + DP (lbs or N)

Where:

TE = Total tractive effort RR = Force necessary to overcome rolling resistance
 GR = Force required to climb a grade FA = Force required to accelerate DP = Drawbar pull required

The components for this equation may be determined using the following steps:

► Step One: Determine Rolling Resistance

Rolling Resistance (RR) is the force necessary to propel a vehicle over a particular surface. It is recommended that the worst possible surface type to be encountered by the vehicle be factored into the equation.

$$RR = \frac{GVW}{1000} \times R \text{ (lb or N)}$$

Where:

GVW = Gross (loaded) vehicle weight (lb or kg)
 R = Surface friction (value from Rolling Resistance)

Example $RR = \frac{1500}{1000} \times 22 \text{ lbs} = 33 \text{ lbs}$

Rolling Resistance			
Concrete (excellent).....	10	Cobbles (ordinary)	55
Concrete (good).....	15	Cobbles (poor)	37
Concrete (poor)	20	Snow (2 inch).....	25
Asphalt (good)	12	Snow (4 inch).....	37
Asphalt (fair)	17	Dirt (smooth).....	25
Asphalt (poor).....	22	Dirt (sandy)	37
Macadam (good).....	15	Mud.....	37 to 150
Macadam (fair)	22	Sand (soft).....	60 to 150
Macadam (poor)	37	Sand (dune).....	160 to 300

► **Step Two: Determine Grade Resistance**

Grade Resistance (GR) is the amount of force necessary to move a vehicle up a hill or “grade.” This calculation must be made using the maximum grade the vehicle will be expected to climb in normal operation.

To convert incline degrees to % Grade:

$$\% \text{ Grade} = [\tan \text{ of angle (degrees)}] \times 100$$

$$GR = \frac{\% \text{ Grade}}{100} \times GVW \text{ (lb or N)}$$

$$\text{Example } RR = \frac{20}{100} \times 1500 \text{ lbs} = 300 \text{ lbs}$$

► **Step Three: Determine Acceleration Force**

Acceleration Force (FA) is the force necessary to accelerate from a stop to maximum speed in a desired time.

$$FA = \frac{MPH \times GVW \text{ (lb)}}{22 \times t} \quad FA = \frac{KPH \times GVW \text{ (N)}}{35.32 \times t}$$

Where:

t = Time to maximum speed (seconds)

$$\text{Example } FA = \frac{5 \times 1500 \text{ lbs}}{22 \times 10} = 34 \text{ lbs}$$

► **Step Four: Determine Drawbar Pull**

Drawbar Pull (DP) is the additional force, if any, the vehicle will be required to generate if it is to be used to tow other equipment. If additional towing capacity is required for the equipment, repeat steps one through three for the towable equipment and sum the totals to determine DP.

► **Step Five: Determine Total Tractive Effort**

The Tractive Effort (TE) is the sum of the forces calculated in steps one through three above. On low speed vehicles, wind resistance can typically be neglected. However, friction in drive components may warrant the addition of 10% to the total tractive effort to insure acceptable vehicle performance.

$$TE = RR + GR + FA + DP \text{ (lb or N)}$$

$$\text{Example } TE = 33 + 300 + 34 + 0 \text{ (lbs)} = 367 \text{ lbs}$$

► **Step Six: Determine Motor Torque**

The Motor Torque (T) required per motor is the Total Tractive Effort divided by the number of motors used on the machine. Gear reduction is also factored into account in this equation.

$$T = \frac{TE \times ri}{M \times G} \text{ lb-in per motor} \quad T = \frac{TE \times rm}{M \times G} \text{ Nm per motor}$$

Where:

M = Number of driving motors

$$\text{Example } T = \frac{367 \times 16}{2 \times 1} \text{ lb-in / motor} = 2936 \text{ lb-in}$$

► **Step Seven: Determine Wheel Slip**

To verify that the vehicle will perform as designed in regards to tractive effort and acceleration, it is necessary to calculate wheel slip (TS) for the vehicle. In special cases, wheel slip may actually be desirable to prevent hydraulic system overheating and component breakage should the vehicle become stalled.

$$TS = \frac{W \times f \times r_i}{G} \quad TS = \frac{W \times f \times r_m}{G}$$

(lb-in per motor) (Nm per motor)

Where:

f = Coefficient of friction

W = Loaded vehicle weight over driven wheel (lb or N)

Example $TS = \frac{425 \times .06 \times 16}{1} \text{ lb-in / motor} = 4080 \text{ lbs}$

Coefficient of friction (f)	
Steel on steel.....	0.3
Rubber tire on dirt	0.5
Rubber tire on a hard surface.....	0.6 - 0.8
Rubber tire on cement	0.7

To determine radial load capacity requirement of motor

When a motor used to drive a vehicle has the wheel or hub attached directly to the motor shaft, it is critical that the radial load capabilities of the motor are sufficient to support the vehicle. After calculating the Total Radial Load (RL) acting on the motors, the result must be compared to the bearing/shaft load charts for the chosen motor to determine if the motor will provide acceptable load capacity and life.

$$RL = \sqrt{W^2 + \left(\frac{T}{r_i}\right)^2} \text{ lb} \quad RL = \sqrt{W^2 + \left(\frac{T}{r_m}\right)^2} \text{ kg}$$

Example $RL = \sqrt{425^2 + \left(\frac{2936}{16}\right)^2} = 463 \text{ lbs}$

Once the maximum motor RPM, maximum torque requirement, and the maximum load each motor must support have been determined, these figures may then be compared to the motor performance charts and to the bearing load curves to choose a series and displacement to fulfill the motor requirements for the application.

INDUCED SIDE LOAD

In many cases, pulleys or sprockets may be used to transmit the torque produced by the motor. Use of these components will create a torque induced side load on the motor shaft and bearings. It is important that this load be taken into consideration when choosing a motor with sufficient bearing and shaft capacity for the application.

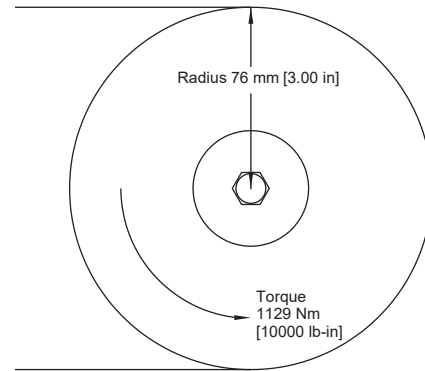

To determine the side load, the motor torque and pulley or sprocket radius must be known. Side load may be calculated using the formula below. The distance from the pulley/sprocket centerline to the mounting flange of the motor must also be determined. These two figures may then be compared to the bearing and shaft load curve of the desired motor to determine if the side load falls within acceptable load ranges.

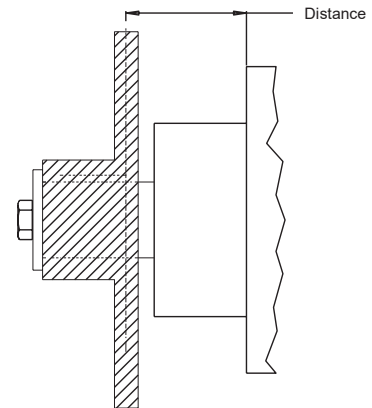

$$\text{Side Load} = \frac{\text{Torque}}{\text{Radius}}$$

$$\text{Side Load} = 14855 \text{ Nm [3333 lbs]}$$

HYDRAULIC EQUATIONS

Multiplication Factor	Abbrev.	Prefix
10 ¹²	T	tera
10 ⁹	G	giga
10 ⁶	M	mega
10 ³	K	kilo
10 ²	h	hecto
10 ¹	da	deka
10 ⁻¹	d	deci
10 ⁻²	c	centi
10 ⁻³	m	milli
10 ⁻⁶	u	micro
10 ⁻⁹	n	nano
10 ⁻¹²	p	pico
10 ⁻¹⁵	f	femto
10 ⁻¹⁸	a	atto

$$\text{Theo. Speed (RPM)} = \frac{1000 \times \text{LPM}}{\text{Displacement (cm}^3/\text{rev)}} \quad \text{or} \quad \frac{231 \times \text{GPM}}{\text{Displacement (in}^3/\text{rev)}}$$

$$\text{Theo. Torque (lb-in)} = \frac{\text{Bar} \times \text{Disp. (cm}^3/\text{rev)}}{20 \text{ pi}} \quad \text{or} \quad \frac{\text{PSI} \times \text{Displacement (in}^3/\text{rev)}}{6.28}$$

$$\text{Power In (HP)} = \frac{\text{Bar} \times \text{LPM}}{600} \quad \text{or} \quad \frac{\text{PSI} \times \text{GPM}}{1714}$$

$$\text{Power Out (HP)} = \frac{\text{Torque (Nm)} \times \text{RPM}}{9543} \quad \text{or} \quad \frac{\text{Torque (lb-in)} \times \text{RPM}}{63024}$$

SHAFT NUT INFORMATION

35MM TAPERED SHAFTS

M24 x 1.5 Thread

A Slotted Nut

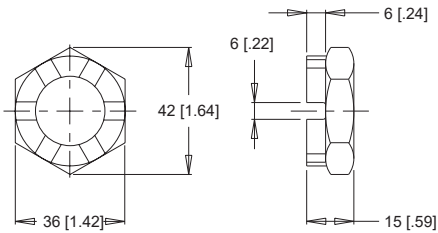

Torque Specifications: 32.5 daNm [240 ft.lb.]

PRECAUTION

The tightening torques listed with each nut should only be used as a guideline. Hubs may require higher or lower tightening torque depending on the material. Consult the hub manufacturer to obtain recommended tightening torque. To maximize torque transfer from the shaft to the hub, and to minimize the potential for shaft breakage, a hub with sufficient thickness must fully engage the taper length of the shaft.

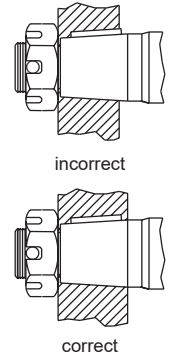

1" TAPERED SHAFTS

3/4-28 Thread

A Slotted Nut

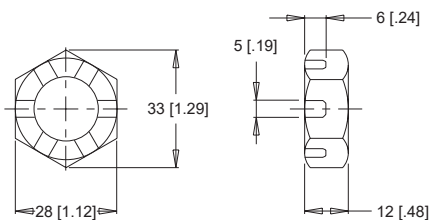

Torque Specifications: 20 - 23 daNm [150 - 170 ft.lb.]

B Lock Nut

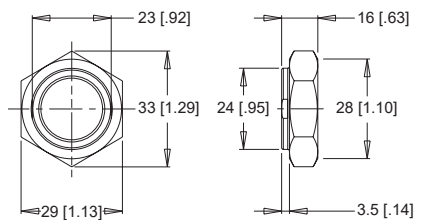

Torque Specifications: 24 - 27 daNm [180 - 200 ft.lb.]

C Solid Nut

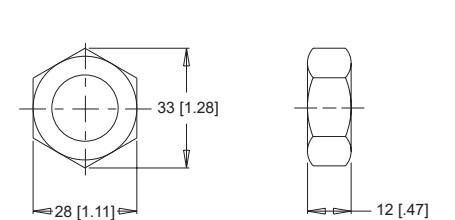

Torque Specifications: 20 - 23 daNm [150 - 170 ft.lb.]

1-1/4" TAPERED SHAFTS

1-20 Thread

A Slotted Nut

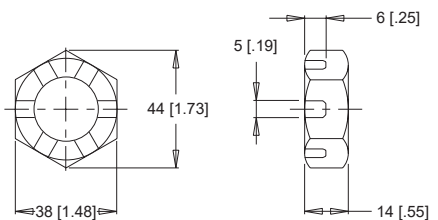

Torque Specifications: 38 daNm [280 ft.lb.] Max.

B Lock Nut

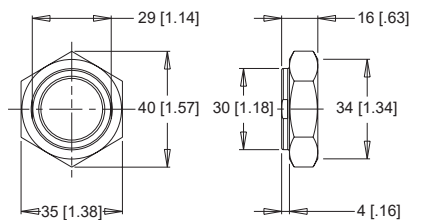

Torque Specifications: 33 - 42 daNm [240 - 310 ft.lb.]

C Solid Nut

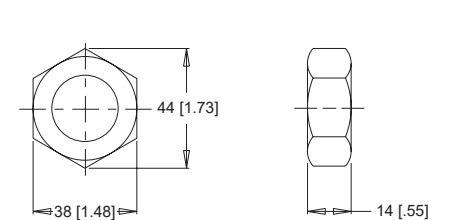

Torque Specifications: 38 daNm [280 ft.lb.] Max.

1-3/8" & 1-1/2" TAPERED SHAFTS

1 1/8-18 Thread

A Slotted Nut

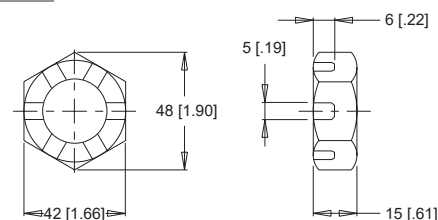

Torque Specifications: 41 - 54 daNm [300 - 400 ft.lb.]

B Lock Nut

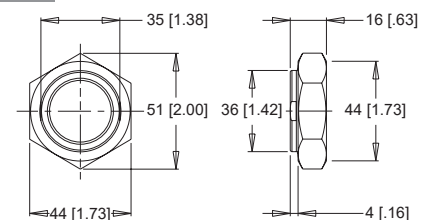

Torque Specifications: 34 - 48 daNm [250 - 350 ft.lb.]

C Solid Nut

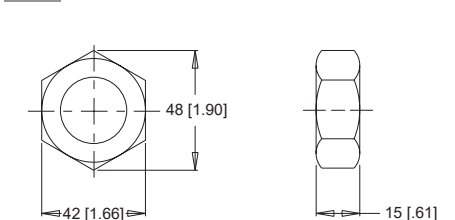

Torque Specifications: 41 - 54 daNm [300 - 400 ft.lb.]

SPEED SENSORS

Impro Fluidtek offers both single and dual element speed sensor options providing a number of benefits to users by incorporating the latest advancements in sensing technology and materials. The single element sensors provide 50 pulses per revolution with the dual element providing 100 pulses per revolution.” Higher resolution is especially beneficial for slow speed applications, where more information is needed for smooth and accurate control. The dual sensor option also provides a direction signal allowing end-users to monitor the direction of shaft rotation.

Unlike competitive designs that breach the high pressure area of the motor to add the sensor, the Impro Fluidtek speed sensor option utilizes an add-on flange to locate all sensor components outside the high pressure operating environment. This eliminates the potential leak point common to competitive designs. Many improvements were made to the sensor flange including changing the material from cast iron to acetal resin, incorporating a Buna-N shaft seal internal to the flange, and providing a grease zerk, which allows the user to fill the sensor cavity with grease. These improvements enable the flange to withstand the rigors of harsh environments.

Another important feature of the new sensor flange is that it is self-centering, which allows it to remain concentric to the magnet rotor. This produces a consistent mounting location for the new sensor module, eliminating the need to adjust

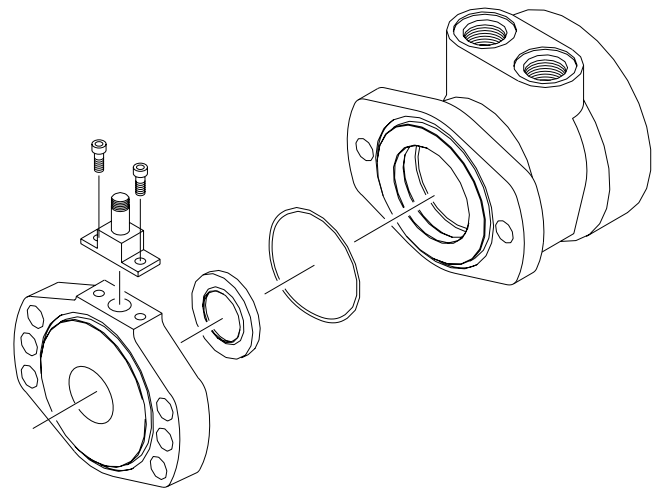

the air gap between the sensor and magnet rotor. The o-ring sealed sensor module attaches to the sensor flange with two small screws, allowing the sensor to be serviced or upgraded in the field in under one minute. This feature is especially valuable for mobile applications where machine downtime is costly. The sensor may also be serviced without exposing the hydraulic circuit to the atmosphere. Another advantage of the self-centering flange is that it allows users to rotate the sensor to a location best suited to their application. This feature is not available on competitive designs, which fix the sensor in one location in relationship to the motor mounting flange.

FEATURES / BENEFITS

- Grease fitting allows sensor cavity to be filled with grease for additional protection.
- Internal extruder seal protects against environmental elements.
- M12 or weatherpack connectors provide installation flexibility.
- Dual element sensor provides up to 100 pulses per revolution and directional sensing.
- Modular sensor allows quick and easy servicing.
- Acetal resin flange is resistant to moisture, chemicals, oils, solvents and greases.
- Self-centering design eliminates need to set magnet-to-sensor air gap.
- Protection circuitry

SENSOR OPTIONS

Z - 4-pin M12 male connector

This option has 50 pulses per revolution on all series. This option will not detect direction.

Y - 3-pin male weatherpack connector*

This option has 50 pulses per revolution on all series. This option will not detect direction.

X - 4-pin M12 male connector

This option has 100 pulses per revolution on all series. This option will detect direction.

W - 4-pin male weatherpack connector*

This option has 100 pulses per revolution on all series. This option will detect direction.

*These options include a 610mm [2 ft] cable.

SPEED SENSORS

SINGLE ELEMENT SENSOR - Y & Z

Supply voltages 7.5-24 Vdc
 Maximum output off voltage 24 V
 Maximum continuous output current < 25 ma
 Signal levels (low, high) 0.8 to supply voltage
 Operating Temp -30°C to 83°C [-22°F to 181°F]

DUAL ELEMENT SENSOR - X & W

Supply voltages 7.5-18 Vdc
 Maximum output off voltage 18 V
 Maximum continuous output current < 20 ma
 Signal levels (low, high) 0.8 to supply voltage
 Operating Temp -30°C to 83°C [-22°F to 181°F]

SENSOR CONNECTORS

Z Option

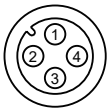

PIN		
1	positive	brown or red
2	n/a	white
3	negative	blue
4	pulse out	black

X Option

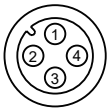

PIN		
1	positive	brown or red
2	direction out	white
3	negative	blue
4	pulse out	black

Y Option

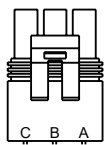

PIN		
A	positive	brown or red
B	negative	blue
C	pulse out	black
D	n/a	white

W Option

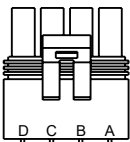

PIN		
A	positive	brown or red
B	negative	blue
C	pulse out	black
D	direction out	white

PROTECTION CIRCUITRY

The single element sensor has been improved and incorporates protection circuitry to avoid electrical damage caused by:

- reverse battery protection
- overvoltage due to power supply spikes and surges (60 Vdc max.)
- power applied to the output lead

The protection circuit feature will help “save” the sensor from damage mentioned above caused by:

- faulty installation wiring or system repair
- wiring harness shorts/opens due to equipment failure or harness damage resulting from accidental conditions (i.e. severed or grounded wire, ice, etc.)
- power supply spikes and surges caused by other electrical/electronic components that may be intermittent or damaged and “loading down” the system.

While no protection circuit can guarantee against any and all fault conditions. The single element sensor from Impro Fluidtek with protection circuitry is designed to handle potential hazards commonly seen in real world applications.

Unprotected versions are also available for operation at lower voltages down to 4.5V.

FREE TURNING ROTOR

The ‘AC’ option or “Free turning” option refers to a specially prepared rotor assembly. This rotor assembly has increased clearance between the rotor tips and rollers allowing it to turn more freely than a standard rotor assembly. For spool valve motors, additional clearance is also provided between the shaft and housing bore. The ‘AC’ option is available for all motor series and displacements.

There are several applications and duty cycle conditions where ‘AC’ option performance characteristics can be beneficial. In continuous duty applications that require high flow/high RPM operation, the benefits are twofold. The additional clearance helps to minimize internal pressure drop at high flows. This clearance also provides a thicker oil film at metal to metal contact areas and can help extend the life of the motor in high RPM or even over speed conditions. The ‘AC’ option should be considered for applications that require continuous operation above 57 LPM [15 GPM] and/or 300 RPM. Applications that are subject to pressure spikes due to frequent reversals or shock loads can also benefit by specifying the ‘AC’ option. The additional clearance serves to act as a buffer against spikes, allowing them to be bypassed through the motor rather than being absorbed and transmitted through the drive link to the output shaft. The trade-off for achieving these benefits is a slight loss of volumetric efficiency at high pressures.

INTERNAL DRAIN

The internal drain is standard on all WD, WP, WR, and WS360. Typically, a separate drain line must be installed to direct case leakage of the motor back to the reservoir when using, WS365/366. However, the internal drain option eliminates the need for a separate drain line through the installation of two check valves in the motor. This simplifies plumbing requirements for the motor.

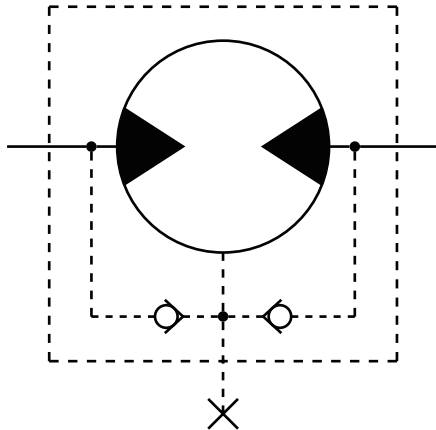

The two check valves connect the case area of the motor to each port of the endcover. During normal motor operation, pressure in the input and return lines of the motor close the check valves. However, when the pressure in the case of the motor is greater than that of the return line, the check valve between the case and low pressure line opens, allowing the case leakage to flow into the return line. Since the operation of the check valves is dependent upon a pressure differential, the internal drain option operates in either direction of motor rotation.

Although this option can simplify many motor installations, precautions must be taken to insure that return line pressure remains below allowable levels (see table below) to insure proper motor operation and life. If return line pressure is higher than allowable, or experiences pressure spikes, this pressure may feed back into the motor, possibly causing catastrophic seal failure. Installing motors with internal drains in series is not recommended unless overall pressure drop over all motors is below the maximum allowable backpressure as listed in the chart below. If in doubt, contact your authorized Impro Fluidtek representative.

MAXIMUM ALLOWABLE BACK PRESSURE		
Series	Cont. bar [psi]	Inter. bar [psi]
WH	69 [1000]	103 [1500]
WT	21 [300]	34 [500]
Brakes	34 [500]	34 [500]

HYDRAULIC DECLUTCH

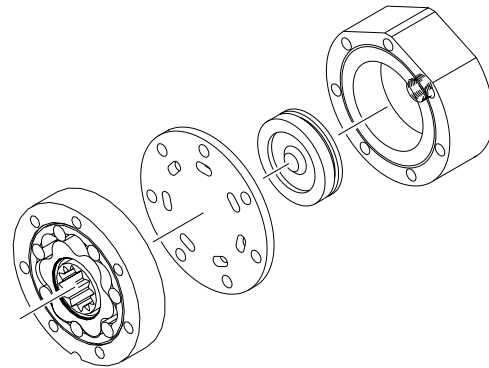

The declutch or 'AE' option, available on the RE and CE Series motors, has been specifically designed for applications requiring the motor to have the ability to "freewheel" when not pressurized. By making minor changes to internal components, the torque required to turn the output shaft is minimal. Selection of this option allows freewheeling speeds up to 1,000 RPM* depending on the displacement of the motor and duty cycle of the application.

To enable the motor to perform this function, the standard rotor assembly is replaced with a freeturn rotor assembly. Next, the standard balance plate and endcover is replaced with a special wear plate and ported endcover. The wear plate features seven holes that connect the stator pockets to each other. The ported endcover features a movable piston capable of sealing the seven holes in the wear plate.

When standard motor function is required, pressure is supplied to the endcover port, moving the piston against the wear plate. This action seals the seven holes allowing the motor to function as normal. However, when pressure is removed from the endcover port, the pressure created by the turning rotor assembly pushes the piston away from the wear plate, opening the rotor pockets to each other. In this condition, oil may circulate freely within the rotor and endcover assemblies, allowing the rotor assembly to rotate freely within the motor.

This option is especially useful in applications ranging from winch drives to towable wheel drives. Depending on the valves and hydraulic circuitry, operation of the freewheel function may be manually or automatically selected. A basic schematic is shown to the right.

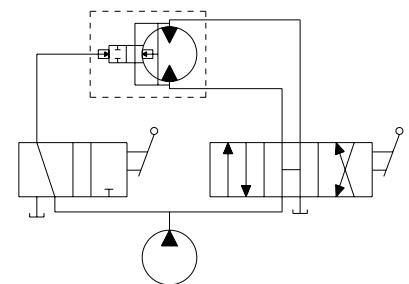

► The 1,000 RPM rating was based on smaller displacement options with forced flow flushing through the motor to provide cooling.

VALVE CAVITY

The valve cavity option provides a cost effective way to incorporate a variety of cartridge valves integral to the motor. The valve cavity is a standard 10 series 2-way cavity that accepts numerous cartridge valves, including over-running check valves, relief cartridges, flow control valves, pilot operated check fuses, and high pressure shuttle valves. Installation of a relief cartridge into the cavity provides an extra margin of safety for applications encountering frequent pressure spikes. Relief cartridges from 69 to 207 bar [1000 to 3000 psi] may also be factory installed.

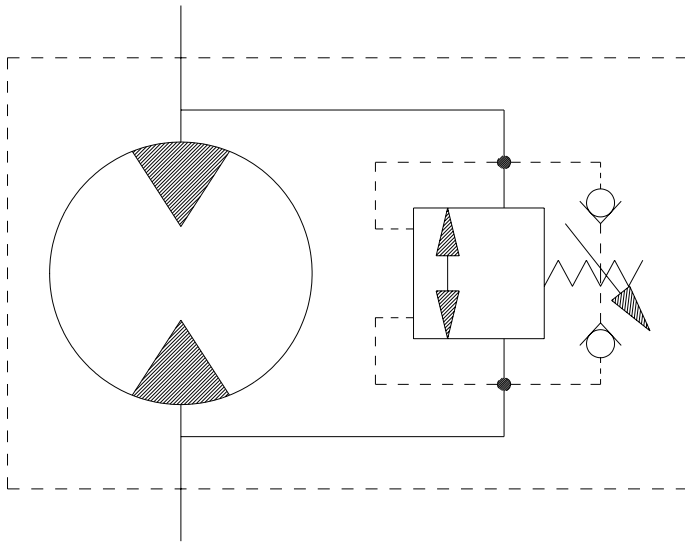

For basic systems with fixed displacement pumps, either manual or motorized flow control valves may be installed into the valve cavity to provide a simple method for controlling motor speed. It is also possible to incorporate the speed sensor option and a programmable logic controller with a motorized flow control valve to create a closed loop, fully automated speed control system. For motors with internal brakes, a shuttle valve cartridge may be installed into the cavity to provide a simple, fully integrated method for supplying release pressure to the pilot line to actuate an integral brake. To discuss other alternatives for the valve cavity option, contact an authorized Impro Fluidtek distributor.

SLINGER SEAL

Slinger seals are available on select series offered by Impro Fluidtek. Slinger seals offer extended shaft/shaft seal protection by prevented a buildup of material around the circumference of the shaft which can lead to premature shaft seal failures. The Impro Fluidtek slinger seals are designed to be larger in diameter than competitive products, providing greater surface speed and 'slinging action'.

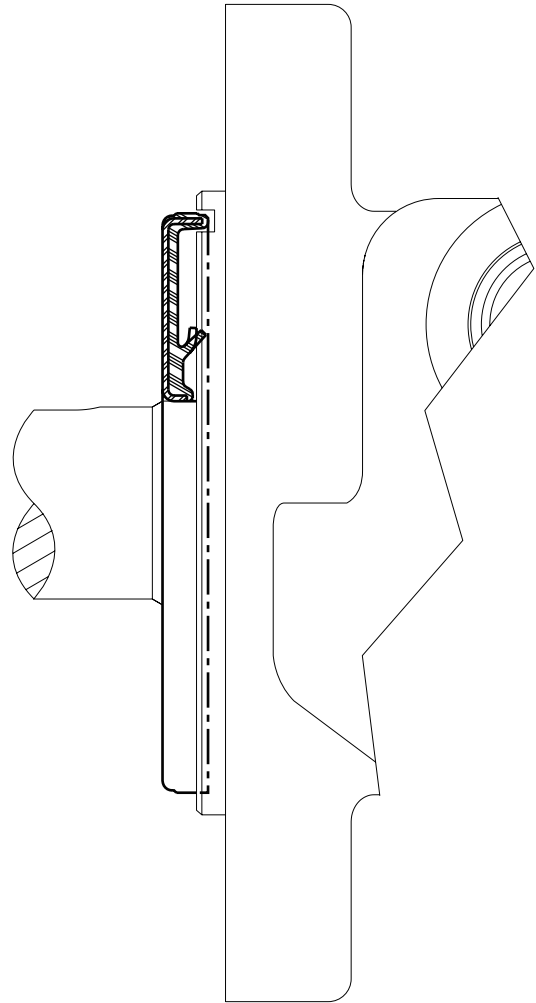

Slinger seals are also available on 4-hole flange mounts on select series. Contact a Impro Fluidtek Customer Service Representative for additional information.

WT (All Series)

Heavy Duty Hydraulic Motor

OVERVIEW

One of the most impressive features of the WT series is its remarkable torque potential despite its compact size. The WT series motor can generate a torque output comparable to that of competing designs, but in a smaller and lighter package. This space and weight efficiency does not compromise durability, as the motor utilizes substantial shafts, bearings, and links to efficiently transmit the powerful torque it produces. Additionally, the use of a drain reduces pressure on the shaft seal while ensuring optimal motor life through proper driveline lubrication. Furthermore, the WT series offers standard mounting and shaft options that are interchangeable with competing designs, and an internal drain option is also available.

700 - Hydraulic Motor Standard

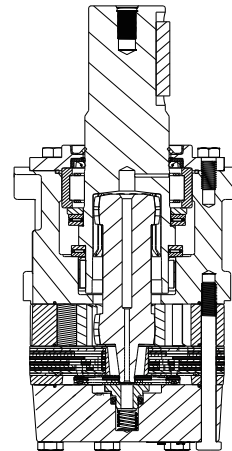

701 - Hydraulic Motor With Wheel Mount

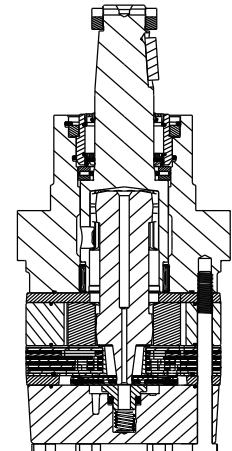

FEATURES / BENEFITS

- Heavy-duty roller bearings for extra side load capacity.
- Best in class power to weight ratio due to compact design.
- A variety of mounts and shafts provide flexibility in application design.
- Heavy-duty drive link receives full flow lubrication to provide long service life.
- Optimized rotor geometry provides highly efficient smooth running performance.
- Three-zone commutator valve results in exceptional volumetric efficiency.
- Standard case and internal drain for extended shaft seal life.

TYPICAL APPLICATIONS

Heavy-duty wheel drives, grain augers, sweepers, construction equipment, feed rollers, mixers, pumping units, conveyors, boring machines, rotators, mining equipment, forestry equipment and more.

SPECIFICATIONS

CODE	Displacement cm ³ [in ³ /rev]	Max. Speed rpm		Max. Flow lpm [gpm]		Max. Torque Nm [lb-in]		Max. Pressure bar [psi]		
		cont.	inter.	cont.	inter.	cont.	inter.	cont.	inter.	peak
300	300 [18.3]	320	376	95 [25]	114 [30]	854 [7554]	983 [8701]	207 [3000]	241 [3500]	259 [3750]
375	375 [22.8]	252	303	95 [25]	114 [30]	105 [9321]	1137 [10066]	207 [3000]	224 [3250]	241 [3500]
470	465 [28.3]	203	243	95 [25]	114 [30]	1078 [9538]	1398 [12367]	173 [2500]	224 [3250]	241 [3500]
540	536 [32.7]	176	211	95 [25]	114 [30]	1285 [11374]	1532 [13556]	173 [2500]	207 [3000]	241 [3500]
750	748 [45.6]	130	155	95 [25]	114 [30]	1835 [16240]	2138 [18923]	173 [2500]	207 [3000]	241 [3500]
930	929 [56.7]	101	122	95 [25]	114 [30]	1794 [15873]	2168 [19188]	138 [2000]	173 [2500]	207 [3000]
1K1	1047 [63.9]	93	112	95 [25]	114 [30]	2041 [18066]	2560 [22654]	138 [2000]	173 [2500]	207 [3000]
1K5	1495 [91.2]	63	75	95 [25]	114 [30]	2123 [18786]	2329 [20613]	104 [1500]	121 [1750]	138 [2000]
2K1	2094 [127.7]	45	40	95 [25]	114 [30]	2668 [23613]	3342 [29580]	104 [1500]	121 [1750]	138 [2000]

► Performance data is typical. Performance of production units varies slightly from one motor to another. See page 7 for additional information on product testing. Running at intermittent ratings should not exceed 10% of every minute of operation.

DISPLACEMENT PERFORMANCE

300		Pressure - bars [psi]						Max. Cont.	Max. Inter.	
		17 [250]	35 [500]	69 [1000]	104 [1500]	138 [2000]	173 [2500]	207 [3000]	241 [3500]	
300 cm ³ [18.3 in ³ /rev.]		Torque - Nm [lb-in], Speed rpm						Intermittent Ratings - 10% of Operation		
Flow - lpm [gpm]	2 [0.5]	54 [476] 4	115 [1014] 3	237 [2100] 2					7	
	4 [1]	47 [415] 11	108 [952] 9	255 [2256] 7	380 [3363] 5	486 [4304] 3			13	
	8 [2]	49 [435] 24	119 [1057] 23	257 [2278] 21	410 [3628] 19	543 [4801] 15	671 [5942] 12	789 [6983] 9	899 [7959] 7	26
	15 [4]	49 [430] 50	120 [1064] 49	264 [2336] 46	409 [3616] 43	554 [4904] 37	701 [6202] 32	839 [7424] 28	971 [8595] 26	51
	23 [6]		116 [1025] 75	278 [2462] 69	420 [3719] 65	567 [5019] 58	712 [6297] 54	854 [7554] 51	983 [8701] 48	76
	30 [8]		105 [929] 100	251 [2222] 97	396 [3506] 93	542 [4793] 86	692 [6122] 78	831 [7353] 70	974 [8621] 69	101
	38 [10]		99 [877] 126	237 [2099] 122	388 [3438] 115	549 [4857] 113	687 [6081] 107	833 [7369] 96	970 [8588] 90	127
	45 [12]		88 [762] 151	237 [2094] 150	378 [3342] 140	527 [4666] 135	666 [5893] 129	823 [7281] 119	963 [8523] 113	152
	53 [14]		77 [679] 176	211 [1864] 175	361 [3191] 172	506 [4478] 164	656 [5802] 156	805 [7121] 151	951 [8420] 140	177
	61 [16]		60 [528] 201	208 [1845] 200	359 [3179] 189	495 [4378] 185	648 [5731] 178	791 [6999] 172	928 [8213] 165	202
	68 [18]			191 [1694] 225	335 [2961] 222	497 [4402] 211	632 [5592] 156	776 [6871] 196	914 [8093] 189	228
	76 [20]			168 [1489] 251	320 [2835] 247	461 [4083] 240	610 [5401] 233	764 [6762] 228	897 [7934] 216	253
	83 [22]			147 [1298] 276	302 [2675] 272	444 [3926] 269	588 [5205] 258	742 [6570] 249	883 [7810] 234	278
	91 [24]			123 [1086] 300	272 [2409] 298	414 [3666] 296	558 [4934] 290	708 [6264] 281	851 [7535] 272	303
95 [25]			108 [958] 315	257 [2278] 313	393 [3482] 308	549 [4857] 300	694 [6139] 289	839 [7421] 280	316	
114 [30]				186 [1642] 376	333 [2945] 372	473 [4189] 369			379	

Overall Efficiency - 70 - 100% 40 - 69% 0 - 39%

Rotor Width

25.4 [1.000]

mm [in]

Theoretical Torque - Nm [lb-in]

82 [729]	165 [1457]	329 [2914]	494 [4371]	659 [5828]	823 [7285]	988 [8742]	1152 [10199]
----------	------------	------------	------------	------------	------------	------------	--------------

Displacement tested at 54°C [129°F] with an oil viscosity of 46cSt [213 SUS]

► Performance data is typical. Performance of production units varies slightly from one motor to another. See page 7 for additional information on product testing.

WT (All Series)

Heavy Duty Hydraulic Motor



DISPLACEMENT PERFORMANCE

375

Pressure - bars [psi]

Max. Cont. Max. Inter.

17 [250]	35 [500]	69 [1000]	104 [1500]	138 [2000]	173 [2500]	207 [3000]	224 [3250]
----------	----------	-----------	------------	------------	------------	------------	------------

375 cm³ [22.8 in³/rev.]

Torque - Nm [lb-in], **Speed rpm**

Intermittent Ratings - 10% of Operation

Flow - lpm [gpm]	2 [0.5]	65 [574] 4	144 [1272] 3	302 [2670] 2	449 [3970] 1					Theoretical rpm
	4 [1]	66 [583] 9	152 [1345] 8	312 [2757] 7	475 [4208] 5	625 [5535] 4				
	8 [2]	67 [596] 19	154 [1365] 18	329 [2907] 17	496 [4388] 14	644 [5695] 12	805 [7122] 10	963 [8524] 8	1050 [9288] 7	11
	15 [4]	71 [627] 40	158 [1400] 39	337 [2982] 37	513 [4536] 34	680 [6020] 30	858 [7596] 27	1013 [8962] 25	1099 [9723] 23	21
	23 [6]	64 [570] 60	151 [1334] 60	336 [2969] 58	520 [4598] 54	694 [6141] 49	871 [7704] 45	1048 [9275] 41	1115 [9867] 41	41
	30 [8]	53 [467] 81	151 [1337] 80	325 [2876] 78	512 [4532] 73	691 [6113] 69	873 [7724] 63	1051 [9304] 60	1126 [9964] 59	61
	38 [10]		131 [1161] 101	313 [2768] 99	502 [4439] 95	686 [6075] 89	884 [7824] 82	1049 [9281] 79	1131 [10011] 77	82
	45 [12]		112 [995] 121	308 [2725] 120	494 [4375] 116	685 [6059] 109	862 [7626] 103	1053 [9321] 98	1137 [10066] 97	102
	53 [14]		99 [878] 141	283 [2508] 140	469 [4149] 136	645 [5705] 131	844 [7467] 125	1013 [8965] 117	1116 [9877] 115	122
	61 [16]		75 [662] 162	262 [2319] 161	443 [3923] 160	631 [5587] 155	823 [7283] 148	1009 [8930] 143	1114 [9859] 136	142
	68 [18]			248 [2198] 181	427 [3779] 178	612 [5416] 175	804 [7119] 167	1005 [8895] 160	1091 [9653] 156	163
	76 [20]			218 [1925] 202	403 [3568] 200	583 [5161] 195	778 [6886] 189	966 [8549] 178	1071 [9474] 173	183
	83 [22]			189 [1676] 222	375 [3318] 221	561 [4967] 217	754 [6669] 211	942 [8335] 201	1036 [9171] 96	203
	91 [24]			155 [1374] 242	344 [3041] 240	535 [4732] 237	724 [6410] 229			223
	95 [25]				321 [2839] 252	519 [4596] 249	710 [6283] 241			244
	114 [30]				238 [2110] 303	432 [3820] 301	622 [5503] 296			254
Max. Max. Inter. Cont.										304

Overall Efficiency - 70 - 100% 40 - 69% 0 - 39%

Rotor Width

31.8 [1.252]

mm [in]

Theoretical Torque - Nm [lb-in]

103 [908]	205 [1815]	410 [3631]	615 [5446]	821 [7261]	1026 [9076]	1231 [10892]	1333 [11799]
-----------	------------	------------	------------	------------	-------------	--------------	--------------

Displacement tested at 54°C [129°F] with an oil viscosity of 46cSt [213 SUS]

► Performance data is typical. Performance of production units varies slightly from one motor to another. See page 7 for additional information on product testing.

DISPLACEMENT PERFORMANCE

470

Pressure - bars [psi]						Max. Cont.	Max. Inter.
17 [250]	35 [500]	69 [1000]	104 [1500]	138 [2000]	173 [2500]	207 [3000]	224 [3250]

465 cm³ [28.3 in³/rev.]

Torque - Nm [lb-in], **Speed rpm** Intermittent Ratings - 10% of Operation

Flow - lpm [gpm]	2 [0.5]	86 [762] 3	201 [1780] 2	401 [3553] 2							5	Theoretical rpm
	4 [1]	92 [817] 7	195 [1728] 7	406 [3597] 6	610 [5395] 5	806 [7137] 4					9	
	8 [2]	94 [835] 15	199 [1761] 15	418 [3702] 14	631 [5580] 13	832 [7365] 11	1042 [9226] 9	1239 [10961] 8			17	
	15 [4]	92 [815] 32	202 [1784] 32	426 [3769] 60	646 [5717] 28	849 [7513] 24	1066 [9430] 23	1272 [11256] 21	1381 [12217] 19		33	
	23 [6]	82 [729] 48	203 [1799] 47	423 [3744] 46	647 [5725] 43	855 [7565] 39	1070 [9473] 36	1275 [11287] 34	1365 [12083] 32		49	
	30 [8]	67 [595] 65	185 [1641] 64	414 [3663] 63	642 [5683] 60	867 [7671] 54	1078 [9538] 47	1300 [11508] 46	1398 [12367] 44		66	
	38 [10]	52 [459] 81	170 [1503] 80	399 [3532] 79	630 [5573] 78	857 [7584] 69	1077 [9531] 63	1283 [11352] 61	1393 [12323] 58		82	
	45 [12]		153 [1354] 97	380 [3366] 96	613 [5422] 93	842 [7454] 88	1072 [9488] 77	1302 [11523] 74	1394 [12334] 68		98	
	53 [14]		127 [1121] 114	359 [3173] 113	591 [5229] 110	823 [7282] 104	1057 [9350] 97	1270 [11242] 89	1392 [12318] 85		114	
	61 [16]		100 [888] 160	335 [2964] 129	564 [4993] 127	798 [7061] 119	1030 [9118] 114	1254 [11101] 108	1369 [12118] 102		131	
	68 [18]		67 [595] 146	304 [2689] 145	535 [4734] 143	765 [6772] 137	1003 [8875] 132	1229 [10877] 120	1348 [11926] 114		147	
	76 [20]			274 [2428] 162	504 [4458] 160	733 [6485] 155	965 [8536] 148	1197 [10592] 139	1318 [11668] 136		164	
	83 [22]			226 [2003] 178	458 [4050] 175	691 [6118] 172	928 [8215] 165	1150 [10181] 156	1266 [11200] 154		180	
	91 [24]			176 [1554] 194	415 [3670] 192	669 [5917] 190	885 [7833] 183				196	
	95 [25]				389 [3442] 203	632 [5589] 198	867 [7676] 190				205	
	114 [30]				277 [2451] 243	514 [4549] 240	755 [6684] 235				245	

Overall Efficiency - 70 - 100% 40 - 69% 0 - 39%

Rotor Width

39.4 [1.553]

Theoretical Torque - Nm [lb-in]

127 [1127]	255 [2253]	509 [4506]	764 [6760]	1018 [9013]	1273 [1126]	1528 [13519]	1655 [14646]
------------	------------	------------	------------	-------------	-------------	--------------	--------------

mm [in]

Displacement tested at 54°C [129°F] with an oil viscosity of 46cSt [213 SUS]

► Performance data is typical. Performance of production units varies slightly from one motor to another. See page 7 for additional information on product testing.

WT (All Series)

Heavy Duty Hydraulic Motor



DISPLACEMENT PERFORMANCE

540

Pressure - bars [psi]				Max. Cont.		Max. Inter.	
17 [250]	35 [500]	69 [1000]	104 [1500]	138 [2000]	173 [2500]	207 [3000]	

536 cm³ [32.7 in³/rev.]

Torque - Nm [lb-in], **Speed rpm** Intermittent Ratings - 10% of Operation

Flow - lpm [gpm]	Torque - Nm [lb-in], Speed rpm								Theoretical rpm
	103 [908] 2	215 [1607] 2	421 [3722] 1						
2 [0.5]	104 [917] 6	228 [2016] 5	454 [4015] 4	666 [5897] 3	874 [7730] 1				4
4 [1]	108 [954] 13	231 [2043] 12	474 [4191] 11	704 [6231] 9	925 [8190] 5	1153 [10201] 4			8
8 [2]	102 [906] 27	232 [2052] 26	503 [4448] 24	756 [6692] 21	994 [8799] 18	1221 [10806] 15	1461 [12930] 13		15
15 [4]	98 [866] 42	230 [2038] 41	498 [4404] 39	766 [6774] 36	1023 [9049] 30	1268 [11225] 27	1494 [13219] 24		29
23 [6]	84 [744] 56	213 [1883] 55	484 [4280] 53	754 [6669] 49	1032 [9130] 42	1273 [11262] 38	1524 [13486] 34		43
30 [8]	63 [561] 70	195 [1727] 69	466 [4122] 68	737 [6519] 64	1006 [8903] 57	1285 [11374] 49	1532 [13556] 46		57
38 [10]	42 [373] 84	179 [1586] 83	444 [3928] 82	717 [6349] 76	984 [8710] 72	1274 [11277] 65	1518 [13436] 57		71
45 [12]		146 [1295] 97	421 [3722] 95	694 [6139] 93	964 [8529] 87	1253 [11091] 80	1512 [13381] 70		85
53 [14]		116 [1025] 113	391 [3460] 111	663 [5865] 108	930 [8230] 103	1206 [10675] 97	1479 [13086] 84		99
61 [16]		90 [798] 127	356 [3153] 125	629 [5563] 123	900 [7969] 116	1192 [10550] 107	1451 [12841] 100		114
68 [18]		56 [498] 141	330 [2923] 139	595 [5265] 137	887 [7850] 133	1158 [10250] 123	1421 [12578] 114		128
76 [20]			278 [2464] 155	549 [4859] 153	822 [7271] 148	1121 [9919] 136	1388 [12283] 133		142
83 [22]			243 [2154] 169	508 [4494] 166	794 [7024] 164	1054 [9325] 156		156	
91 [24]			220 [1948] 176	486 [4299] 174	762 [6741] 169	1025 [9075] 163		170	
95 [25]			90 [800] 211	366 [3237] 210	638 [5649] 207	920 [8144] 203		177	
114 [30]								212	

Overall Efficiency - 70 - 100% 40 - 69% 0 - 39%

Rotor Width

45.5 [1.791]

Theoretical Torque - Nm [lb-in]

147 [1302]	294 [2604]	588 [5207]	883 [7811]	1177 [10414]	1471 [13018]	1765 [15621]
------------	------------	------------	------------	--------------	--------------	--------------

mm [in] Displacement tested at 54°C [129°F] with an oil viscosity of 46cSt [213 SUS]

► Performance data is typical. Performance of production units varies slightly from one motor to another. See page 7 for additional information on product testing.

DISPLACEMENT PERFORMANCE

750		Pressure - bars [psi]				Max. Cont.		Max. Inter.		
		17 [250]	35 [500]	69 [1000]	104 [1500]	138 [2000]	173 [2500]	207 [3000]		
748cm ³ [45.6 in ³ /rev.]		Torque - Nm [lb-in], Speed rpm				Intermittent Ratings - 10% of Operation				
Flow - lpm [gpm]	2 [0.5]	155 [1368] 3	322 [2850] 2						3	Theoretical rpm
	4 [1]	166 [1467] 5	345 [3050] 5	663 [5866] 5					6	
	8 [2]	179 [1585] 11	373 [3304] 11	736 [6515] 10	1105 [9779] 9				11	
	15 [4]	169 [1492] 20	369 [3264] 20	732 [6480] 19	1102 [9749] 18	1439 [12738] 15	1731 [15321] 12		21	
	23 [6]	163 [1446] 31	362 [3202] 31	729 [6456] 30	1124 [9949] 29	1482 [13113] 25	1779 [15754] 19	2101 [18595] 13	31	
	30 [8]	155 [1371] 41	348 [3084] 41	714 [6318] 40	1087 [9617] 39	1473 [13034] 35	1835 [16245] 26	2138 [18924] 19	41	
	38 [10]	144 [1273] 52	334 [2952] 52	702 [6216] 51	1075 [9517] 50	1454 [12876] 46	1826 [16161] 36	2130 [18855] 27	51	
	45 [12]	136 [1199] 61	331 [2926] 61	697 [6167] 60	1078 [9539] 58	1428 [12636] 54	1806 [15985] 44	2113 [18702] 35	61	
	53 [14]	120 [1064] 73	309 [2738] 72	676 [5981] 71	1056 [9343] 70	1426 [12618] 65	1789 [15835] 55	2118 [18748] 44	71	
	61 [16]	100 [883] 84	299 [2649] 83	660 [5841] 82	1069 [9458] 80	1421 [12579] 73	1793 [15868] 64	2096 [18550] 54	82	
	68 [18]	87 [766] 93	283 [2506] 92	652 [5770] 91	1031 [9122] 88	1417 [12539] 85	1750 [15489] 77	2084 [18445] 65	92	
	76 [20]	66 [581] 104	252 [2228] 104	620 [5491] 103	1000 [8850] 101	1375 [12167] 97	1743 [15425] 88	2068 [18299] 77	102	
	83 [22]		241 [2134] 113	610 [5396] 112	999 [8840] 110	1362 [12056] 105	1700 [15047] 96	2044 [18087] 84	112	
	91 [24]		213 [1889] 124	569 [5034] 123	970 [8581] 121	1331 [11778] 116	1684 [14901] 108	2030 [17970] 95	122	
95 [25]		184 [1632] 130	548 [4849] 129	933 [8257] 128	1288 [11397] 124	1648 [14585] 113	1994 [17645] 100	127		
Max. Inter.	114 [30]		481 [4260] 155	854 [7556] 153	1218 [10783] 149	1578 [13963] 141	1927 [17056] 129	152		

Overall Efficiency - 70 - 100% 40 - 69% 0 - 39%

Rotor Width

63.5 [2.501]

mm [in]

Theoretical Torque - Nm [lb-in]

205 [1815]	410 [3631]	821 [7261]	1231 [10892]	1641 [14522]	2051 [18153]	2462 [21783]
------------	------------	------------	--------------	--------------	--------------	--------------

Displacement tested at 54°C [129°F] with an oil viscosity of 46cSt [213 SUS]

► Performance data is typical. Performance of production units varies slightly from one motor to another. See page 7 for additional information on product testing.

WT (All Series)

Heavy Duty Hydraulic Motor



DISPLACEMENT PERFORMANCE

		Pressure - bars [psi]						Max. Cont.		Max. Inter.			
930		17 [250]	35 [500]	52 [750]	69 [1000]	86 [1250]	104 [1500]	121 [1750]	138 [2000]	155 [2250]	173 [2500]		
929cm ³ [56.7 in ³ /rev.]		Torque - Nm [lb-in], Speed rpm						Intermittent Ratings - 10% of Operation					
Flow - lpm [gpm]	2 [0.5]	180 [1590] 1	387 [3423] 1	607 [5368] 1	801 [7089] 1							3	Theoretical rpm
	4 [1]	196 [1734] 4	418 [3696] 3	653 [5780] 3	864 [7649] 3	1067 [9447] 3	1294 [11451] 3					5	
	8 [2]	205 [1816] 8	442 [3907] 7	680 [6015] 7	877 [7764] 7	1117 [9886] 7	1300 [11501] 6	1510 [13365] 5				9	
	15 [4]	198 [1753] 16	432 [3825] 16	664 [5878] 15	906 [8021] 15	1121 [9924] 15	1338 [11840] 14	1556 [13769] 13	1730 [15306] 11			17	
	23 [6]	185 [1633] 24	420 [3719] 24	651 [5765] 24	908 [8034] 24	1123 [9935] 23	1355 [11991] 22	1543 [13651] 20	1794 [15873] 18	1981 [17532] 16		25	
	30 [8]	162 [1438] 32	404 [3576] 31	636 [5624] 30	893 [7900] 30	1107 [9800] 29	1340 [11854] 28	1581 [13988] 27	1776 [15716] 24	1985 [17570] 22	2105 [18632] 17	33	
	38 [10]	125 [1109] 40	368 [3253] 40	626 [5536] 39	845 [7476] 38	1087 [9620] 38	1314 [11625] 36	1497 [13251] 34	1736 [15364] 31	1956 [17306] 28	2153 [19054] 24	41	
	45 [12]	91 [807] 48	341 [3018] 47	578 [5111] 46	815 [7213] 45	1072 [9487] 44	1314 [11630] 42	1525 [13492] 41	1713 [15159] 36	1946 [17222] 33	2133 [18873] 32	49	
	53 [14]	35 [310] 57	290 [2565] 56	533 [4715] 55	765 [6772] 54	1024 [9059] 52	1240 [10974] 50	1487 [13155] 49	1727 [15287] 45	1945 [17216] 43	2168 [19188] 36	58	
	61 [16]		239 [2118] 64	484 [4281] 63	726 [6429] 62	959 [8488] 61	1210 [10708] 59	1450 [12830] 57	1696 [15008] 54	1925 [17039] 50	2140 [18934] 46	66	
	68 [18]		205 [1811] 72	440 [3891] 72	701 [6202] 70	920 [8143] 69	1177 [10418] 67	1422 [12580] 65	1643 [14538] 64	1893 [16741] 58	2105 [18625] 55	74	
	76 [20]		150 [1325] 81	409 [3616] 80	632 [5590] 79	801 [7091] 78	1100 [9733] 76	1505 [12135] 75	1599 [14148] 72	1859 [16454] 67	2060 [18230] 63	82	
	83 [22]		99 [875] 89	336 [2977] 88	581 [5139] 87	837 [7403] 86	1056 [9342] 83	1305 [11553] 83	1561 [13816] 80	1799 [15918] 77	2025 [17925] 71	90	
	91 [24]			282 [2497] 97	501 [4438] 96	766 [6778] 94	1021 [9038] 93	1266 [11201] 92	1489 [13179] 89	1752 [15505] 86	1969 [17427] 82	98	
95 [25]			241 [2137] 101	496 [4389] 100	722 [6390] 100	974 [8621] 97	1214 [10743] 96	1454 [12863] 93	1727 [15286] 89	1956 [17309] 84	102		
114 [30]			66 [582] 122	300 [2652] 121	532 [4711] 120	781 [6914] 118	1044 [9235] 118	1271 [11248] 116			123		

Overall Efficiency - 70 - 100% 40 - 69% 0 - 39%

Rotor Width

78.9 [3.106]

Theoretical Torque - Nm [lb-in]

255 [2257]	510 [4514]	765 [6771]	1020 [9029]	1275 [11286]	1530 [13543]	1785 [15800]	2040 [18057]	2296 [20314]	2551 [22572]
------------	------------	------------	-------------	--------------	--------------	--------------	--------------	--------------	--------------

mm [in]

Displacement tested at 54°C [129°F] with an oil viscosity of 46cSt [213 SUS]

► Performance data is typical. Performance of production units varies slightly from one motor to another. See page 7 for additional information on product testing.

WT (All Series)

Heavy Duty Hydraulic Motor



DISPLACEMENT PERFORMANCE

1K5		Pressure - bars [psi]				Max. Cont.	Max. Inter.		
		17 [250]	35 [500]	52 [750]	69 [1000]	86 [1250]	104 [1500]	121 [1750]	
1495cm ³ [91.2in ³ /rev.]		Torque - Nm [lb-in], Speed rpm				Intermittent Ratings - 10% of Operation			
Flow - lpm [gpm]	2 [0.5]	305 [2703] 0.9	648 [5736] 0.6					2	
	4 [1]	336 [2978] 2	693 [6128] 1	1011 [8942] 1				3	
	8 [2]	351 [3106] 4	729 [6454] 4	1085 [9597] 3	1364 [12072] 3			6	
	15 [4]	331 [2925] 9	712 [6304] 9	1116 [9879] 8	1491 [13191] 7	1771 [15668] 7		11	
	23 [6]	297 [2629] 15	681 [3023] 14	1088 [9632] 13	1464 [12952] 12	1770 [15662] 10		16	
	30 [8]	247 [2183] 20	640 [5662] 19	1038 [9188] 18	1430 [12655] 17	1793 [15864] 15	2123 [18786] 9	21	
	38 [10]	197 [1740] 25	583 [5159] 24	1001 [8860] 23	1377 [12189] 22	1749 [15479] 19	2090 [18498] 14	26	
	45 [12]	131 [1157] 30	531 [4695] 29	940 [8315] 28	1330 [11770] 27	1702 [15066] 24	2041 [18059] 19	2329 [20613] 14	31
	53 [14]	67 [594] 36	484 [4282] 35	869 [7689] 33	1267 [11217] 32	1642 [14532] 30	1990 [17612] 24	2300 [20353] 15	36
	61 [16]		391 [3457] 40	769 [6805] 39	1172 [10374] 37	1567 [13866] 36	1914 [16941] 32	2258 [19986] 21	41
	68 [18]		294 [2602] 45	686 [6072] 44	1076 [9523] 43	1489 [13177] 40	1846 [16334] 38	2188 [19366] 27	46
	76 [20]		182 [1607] 50	614 [5435] 49	988 [8746] 48	1392 [12320] 47	1743 [15429] 44	2301 [18553] 37	51
	83 [22]		87 [770] 55	487 [4310] 54	872 [7720] 53	1283 [11356] 52	1632 [14442] 48	2021 [17883] 46	56
	91 [24]			456 [4032] 60	749 [6632] 60	1146 [10143] 58	1533 [13570] 58	1872 [16568] 50	61
	95 [25]			293 [2589] 63	704 [6232] 62	1052 [9313] 62	1465 [12961] 59	1843 [16306] 53	64
	114 [30]				246 [2174] 75	645 [5711] 74	1047 [9265] 73		76

Overall Efficiency - 70 - 100% 40 - 69% 0 - 39%

Rotor Width

127.1
[5.003]

mm [in]

Theoretical Torque - Nm [lb-in]

410 [3631] 821 [7261] 1231 [10892] 1641 [14522] 2051 [18153] 2462 [21783] 2872 [25414]

Displacement tested at 54°C [129°F] with an oil viscosity of 46cSt [213 SUS]

► Performance data is typical. Performance of production units varies slightly from one motor to another. See page 7 for additional information on product testing.

DISPLACEMENT PERFORMANCE

		Pressure - bars [psi]				Max. Cont.	Max. Inter.	
2K1		17 [250]	35 [500]	52 [750]	69 [1000]	86 [1250]	104 [1500]	121 [1750]

2094cm ³ [127.7in ³ /rev.]		Torque - Nm [lb-in], Speed rpm				Intermittent Ratings - 10% of Operation			
Flow - lpm [gpm]	2 [0.5]	438 [3878] 0.8	892 [7894] 0.8					1	Theoretical rpm
	4 [1]	440 [3891] 1	922 [8162] 1	1398 [12375] 1				2	
	8 [2]	460 [4073] 3	956 [8458] 3	1460 [12923] 3				4	
	15 [4]	443 [3920] 7	963 [8525] 7	1491 [13192] 6	1980 [17520] 6			8	
	23 [6]	402 [3560] 10	924 [8179] 10	1470 [13012] 10	1963 [17370] 9			11	
	30 [8]	337 [2985] 14	884 [7824] 14	1425 [12613] 14	1920 [16995] 13	2390 [21152] 9	2668 [23613] 8	15	
	38 [10]	275 [2431] 17	814 [7205] 17	1350 [11944] 16	1869 [16538] 16	2343 [20733] 13	2663 [23564] 9	19	
	45 [12]	173 [1535] 21	723 [6398] 21	1262 [11171] 21	1795 [15886] 20	2286 [20232] 17	2665 [23588] 12	22	
	53 [14]	66 [587] 25	619 [5479] 24	1155 [10221] 24	1702 [15063] 23	2206 [19519] 21	2637 [23333] 13	26	
	61 [16]		496 [4391] 28	1018 [9009] 28	1587 [14046] 27	2107 [18645] 26	2574 [22777] 20	29	
	68 [18]		368 [3257] 32	910 [8052] 32	1466 [12973] 31	1980 [17527] 30	2471 [21866] 26	33	
	76 [20]		225 [1991] 36	755 [6686] 36	1304 [11537] 36	1859 [16449] 35	2359 [20878] 30	37	
	83 [22]		71 [628] 39	622 [5507] 39	1171 [10367] 39	1682 [14885] 38	2212 [19575] 36	40	
	91 [24]			429 [3794] 43	984 [8704] 43	1544 [13665] 42	2067 [18291] 40	44	
	95 [25]			354 [3129] 45	891 [7883] 45	1428 [12636] 45	1971 [17445] 43	46	
	114 [30]				430 [3803] 54	959 [8485] 54	1492 [13207] 53	55	

Overall Efficiency - 70 - 100% 40 - 69% 0 - 39%

Rotor Width	Theoretical Torque - Nm [lb-in]						
177.9 [7.003]	574 [5084]	1149 [10167]	1723 [15251]	2298 [20334]	2872 [25418]	3447 [30502]	4021 [35585]

mm [in] Displacement tested at 54°C [129°F] with an oil viscosity of 46cSt [213 SUS]

► Performance data is typical. Performance of production units varies slightly from one motor to another. See page 7 for additional information on product testing.

WT (700 Series)

Heavy Duty Hydraulic Motor

HOUSINGS

4-HOLE, SAE C MOUNT

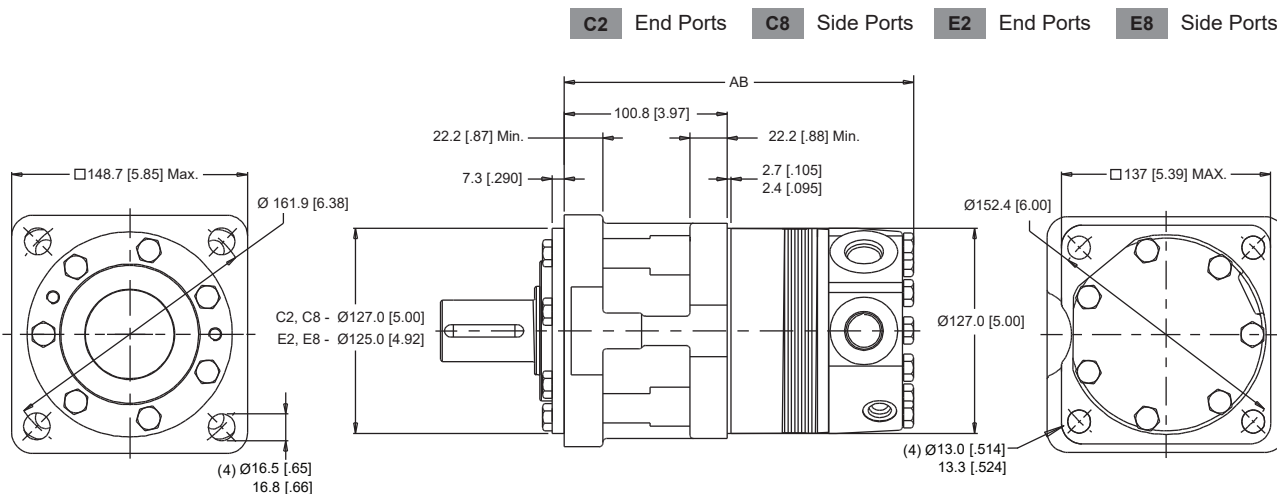

- ▶ Porting options listed on pages 29-30.
- ▶ Dimensions shown are without paint. Paint thickness can be up to 0.13 [.005].

TECHNICAL INFORMATION

ALLOWABLE SHAFT LOAD / BEARING CURVE

The bearing curve represents allowable bearing loads based on ISO 281 bearing capacity for an L_{10} life of 2,000 hours at 100 RPM. Radial loads for speeds other than 100 RPM may be calculated using the multiplication factor table on page 8.

SAE C MOUNTS

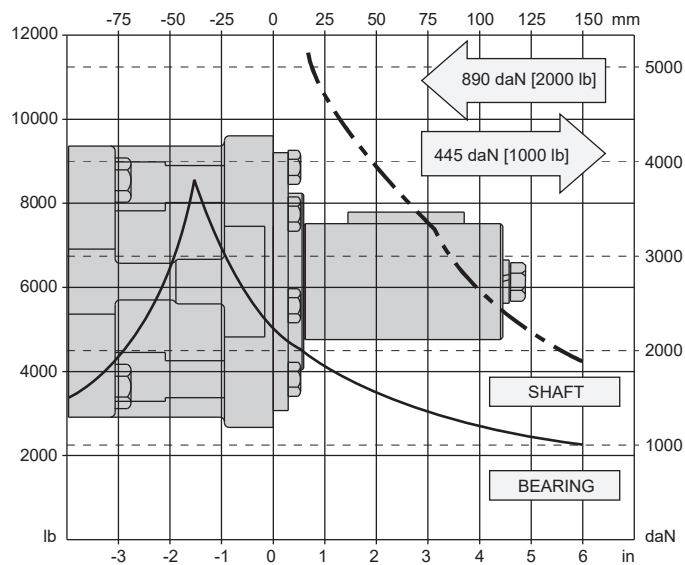

LENGTH & WEIGHT CHART

Dimension AB is the overall motor length from the rear of the motor to the mounting surface.

AB	Endcovers on pg. 29 mm [in]	Endcovers on pg. 30 mm [in]	Weight kg [lb]
300	206 [8.14]	209 [8.25]	20.2 [44.6]
375	213 [8.39]	216 [8.50]	20.8 [45.8]
470	220 [8.69]	223 [8.80]	21.4 [47.1]
540	227 [8.93]	230 [9.04]	21.9 [48.2]
750	245 [9.64]	248 [9.75]	23.3 [51.3]
930	260 [10.24]	263 [10.35]	24.4 [53.8]
1K1	270 [10.64]	273 [10.75]	25.3 [55.7]
1K5	308 [12.14]	311 [12.25]	28.3 [62.5]
2K1	359 [14.14]	362 [14.25]	32.3 [71.3]

- ▶ All WT series motor weights can vary ± 1.4 kg [3 lb] depending on model configurations such as housing, shaft, endcover, options etc.

PORTING

END PORTED - OFFSET

1 Main Ports **A, B:** 7/8 - 14 UNF
Drain Port **C:** 7/16 - 20 UNF

A Main Ports **A, B:** 1/2 - 14 BSP.F
Drain Port **C:** 1/4 - 19 BSP.F

STANDARD

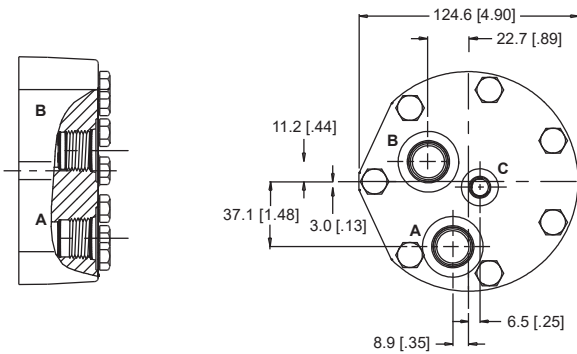

OPTIONAL

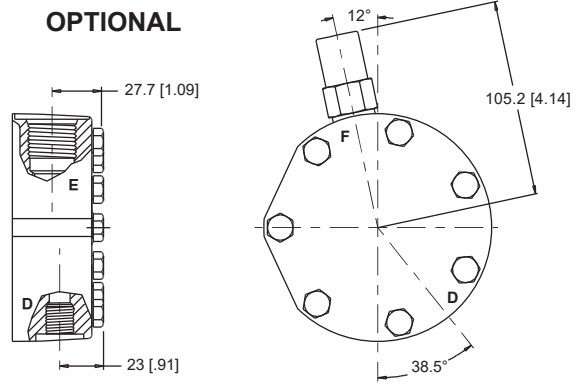

D: Internal Drain **E:** 10 Series/2-Way Valve Cavity 7/8-14 UNF **F:** Valve Cartridge Installed

SIDE PORTED - RADIAL

2 Main Ports **A, B:** G 3/4
Drain Port **C:** G 1/4

5 Main Ports **A, B:** 1 1/16 - 12 UN
Drain Port **C:** 7/16 - 20 UNF

STANDARD

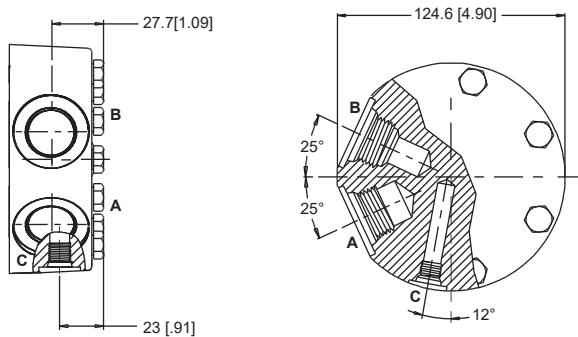

OPTIONAL

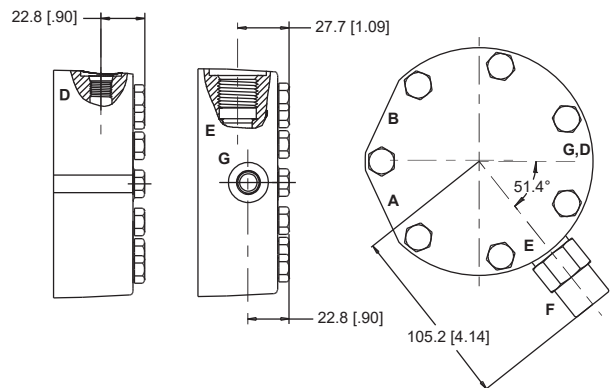

D: Internal Drain **E:** 10 Series/2-Way Valve Cavity 7/8-14 UNF
G: Internal Drain Placement With Valve Cavity **F:** Valve Cartridge Installed

► Dimensions shown are without paint. Paint thickness can be up to 0.13 [0.005].

WT (700 Series)

Heavy Duty Hydraulic Motor

PORTING

SIDE PORTED - MANIFOLD ALIGNED

3 Main Ports **A, B:** 11/16" Drilled
 Drain Port **C:** 7/16 - 20 UNF

STANDARD

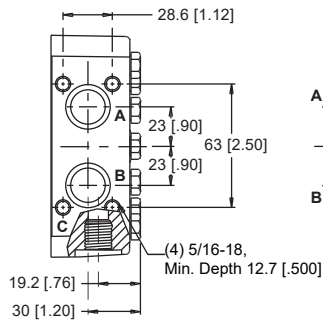

OPTIONAL

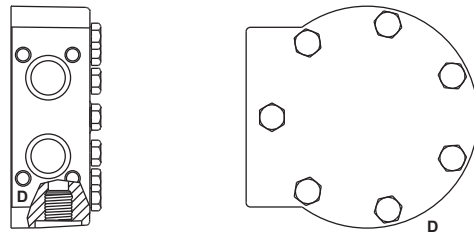

D: Internal Drain

SIDE PORTED - ALIGNED

6 Main Ports **A, B:** 1 1/16 - 12 UN
 Drain Port **C:** 7/16 - 20 UNF

7 Main Ports **A, B:** G 3/4
 Drain Port **C:** G 1/4

STANDARD

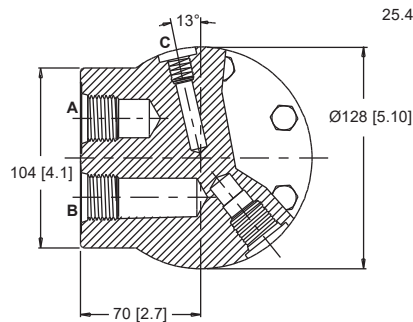
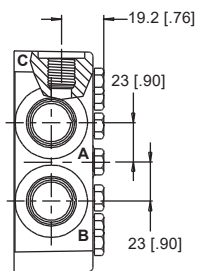

OPTIONAL

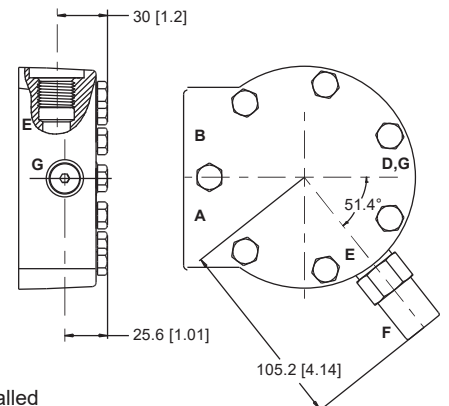

D: Internal Drain E: 10 Series/2-Way Valve Cavity 7/8-14 UNF
 G: Internal Drain Placement With Valve Cavity

F: Valve Cartridge Installed

► Dimensions shown are without paint. Paint thickness can be up to 0.13 [0.005].

SHAFTS

09 14 Tooth Spline Extended **23** 14 Tooth Spline

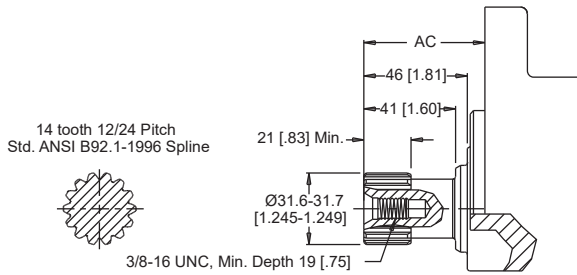

Max. Torque: 2070 Nm [18400 lb-in]

34 17 Tooth Spline (1.5")

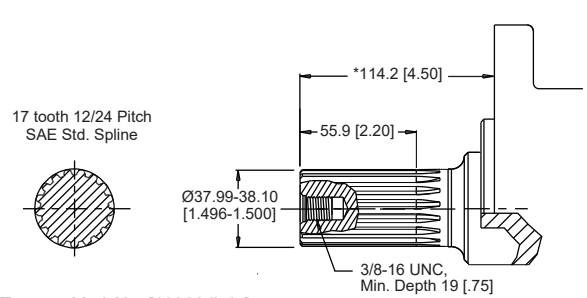

Max. Torque: 2250 Nm [19900 lb-in]

30 1-1/2" Straight Short **32** 1-1/2" Straight

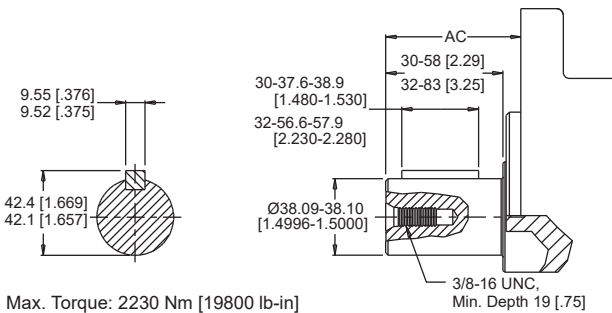

Max. Torque: 2230 Nm [19800 lb-in]

36 40mm Straight **54** 40mm Straight Extended

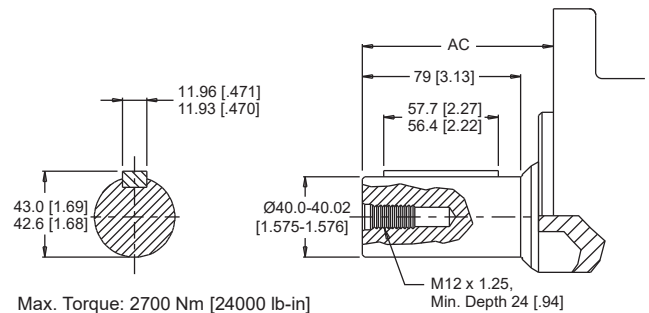

Max. Torque: 2700 Nm [24000 lb-in]

31 1-1/2" Tapered

▶ A slotted hex nut is standard on this shaft. Dimensional details & additional options are listed on page 13.

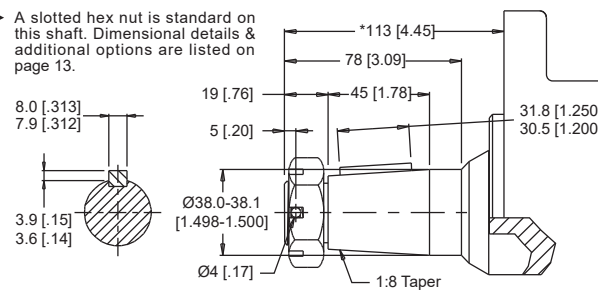

Max. Torque: 2250 Nm [19900 lb-in]

40 2-1/4" Straight

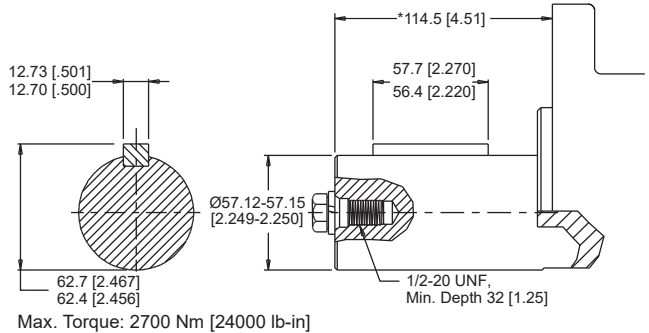

Max. Torque: 2700 Nm [24000 lb-in]

33 17 Tooth Spline **49** 17 Tooth Spline Extended

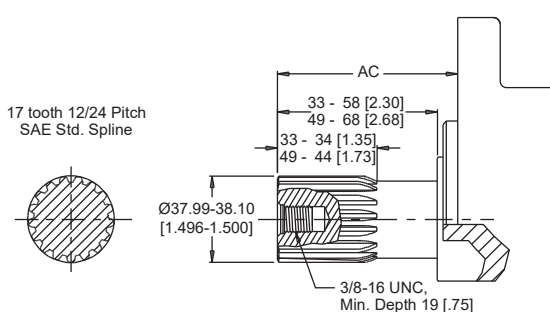

Max. Torque: 2250 Nm [19900 lb-in]

▶ Dimension AC is charted on page 32.

41 50mm Straight

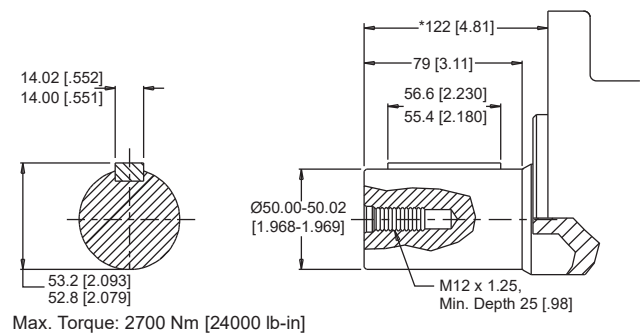

Max. Torque: 2700 Nm [24000 lb-in]

WT (700 Series)

Heavy Duty Hydraulic Motor

SHAFTS

42 16 Tooth Spline

16 tooth 8/16 Pitch
Std. ANSI B92.1-1996 Spline -
Deviates From Standard

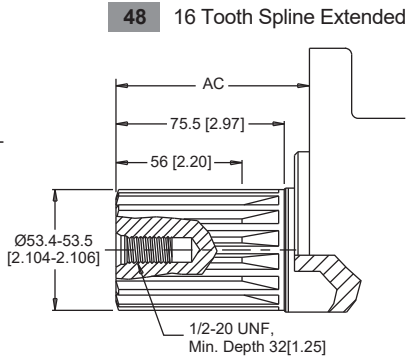
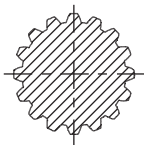

Max. Torque: 2700 Nm [24000 lb-in]

48 16 Tooth Spline Extended

45 60mm Tapered

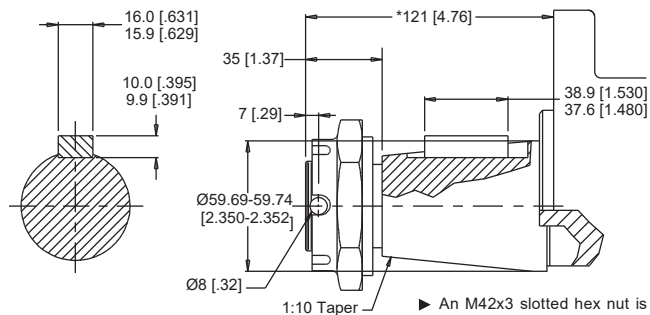

Max. Torque: 2700 Nm [24000 lb-in]

47 2-1/4" Straight

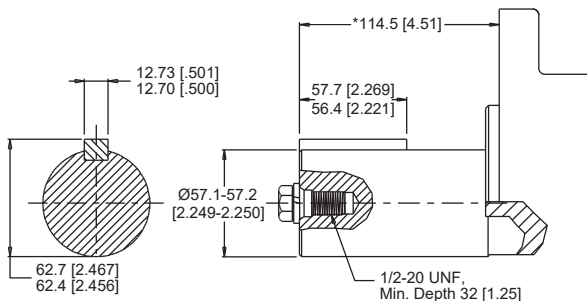

Max. Torque: 2700 Nm [24000 lb-in]

MOUNTING / SHAFT LENGTH CHART

Dimension AC is the overall distance from the motor mounting surface to the end of the shaft and is referenced on detailed shaft drawings on page 31.

AC	Length mm [in]	AC	Length mm [in]
09	86 [3.38]	36	113 [4.45]
23	64.7 [2.55]	42	91 [3.57]
30	77 [3.02]	48	121 [4.77]
32	113 [4.45]	49	108.5 [4.27]
33	78 [3.07]	54	121 [4.78]

► Shaft lengths vary ± 0.8 mm [.030 in.]

ORDERING INFORMATION



1. CHOOSE SERIES DESIGNATION

700 Standard Motor

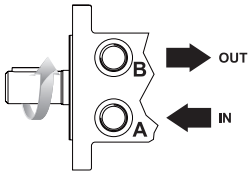

► The 700 series is bi-directional. Reversing the inlet hose will reverse shaft rotation.

2. SELECT A DISPLACEMENT OPTION

300	300 cm ³ /rev [18.3 in ³ /rev]	930	929 cm ³ /rev [56.7 in ³ /rev]
375	374 cm ³ /rev [22.8 in ³ /rev]	1K1	1047 cm ³ /rev [63.9 in ³ /rev]
470	464 cm ³ /rev [28.3 in ³ /rev]	1K5	1495 cm ³ /rev [91.2 in ³ /rev]
540	536 cm ³ /rev [32.7 in ³ /rev]	2K1	2093 cm ³ /rev [127.7 in ³ /rev]
750	747 cm ³ /rev [45.6 in ³ /rev]		

3a. SELECT MOUNT TYPE

▼ END MOUNTS

C2	SAE C Mount (5" Pilot)
E2	SAE C Mount (125mm Pilot)

▼ SIDE MOUNTS

C8	SAE C Mount (5" Pilot)
E8	SAE C Mount (125mm Pilot)

3b. SELECT PORT SIZE

▼ END PORT OPTIONS

1	7/8-14 UNF Offset
A	1/2" BSP

▼ SIDE PORT OPTIONS

2	G 3/4, Radial
3	1 1/16" Hole, Aligned Manifold
5	1 1/16-12 UN, Radial
6	1 1/16-12 UN, Aligned
7	G 3/4, Aligned

4. SELECT A SHAFT OPTION

09	14 Tooth Spline Extended	40	2-1/4" Straight
23	14 Tooth Spline	41	50mm Straight
30	1-1/2" Straight Short	42	16 Tooth Spline
31	1-1/2" Tapered	45	60mm Tapered
32	1-1/2" Straight	47	2-1/4" Straight
33	17 Tooth Spline	48	16 Tooth Spline Extended
34	17 Tooth Spline (1.5")	49	17 Tooth Spline Extended
36	40mm Straight	54	40mm Straight Extended

► For options not listed in the table above, please contact us with your requirements.

5. SELECT A PAINT OPTION

A	Black
B	Black, Unpainted Mounting Surface
Z	No Paint

6. SELECT A VALVE CAVITY / CARTRIDGE OPTION

A	None	F	121 bar [1750 psi] Relief
B	Valve Cavity Only	G	138 bar [2000 psi] Relief
C	69 bar [1000 psi] Relief	J	173 bar [2500 psi] Relief
D	86 bar [1250 psi] Relief	L	207 bar [3000 psi] Relief
E	104 bar [1500 psi] Relief		

► Valve cavity is not available on port option 3.

7. SELECT AN ADD-ON OPTION

A	Standard
B	Lock Nut
C	Solid Hex Nut
W	Speed Sensor, Dual, 4-Pin Male Weatherpack Connector
X	Speed Sensor, Dual, 4-Pin M12 Male Connector
Y	Speed Sensor, Single, 3-Pin Male Weatherpack Connector
Z	Speed Sensor, Single, 4-Pin M12 Male Connector

8. SELECT A MISCELLANEOUS OPTION

AA	None
AB	Check Valve Integrated
AC	Freeturning Rotor
AD	Internal Drain & Freeturning Rotor

WT (701 Series)

Heavy Duty Hydraulic Motor

HOUSINGS

4-HOLE, WHEEL MOUNT

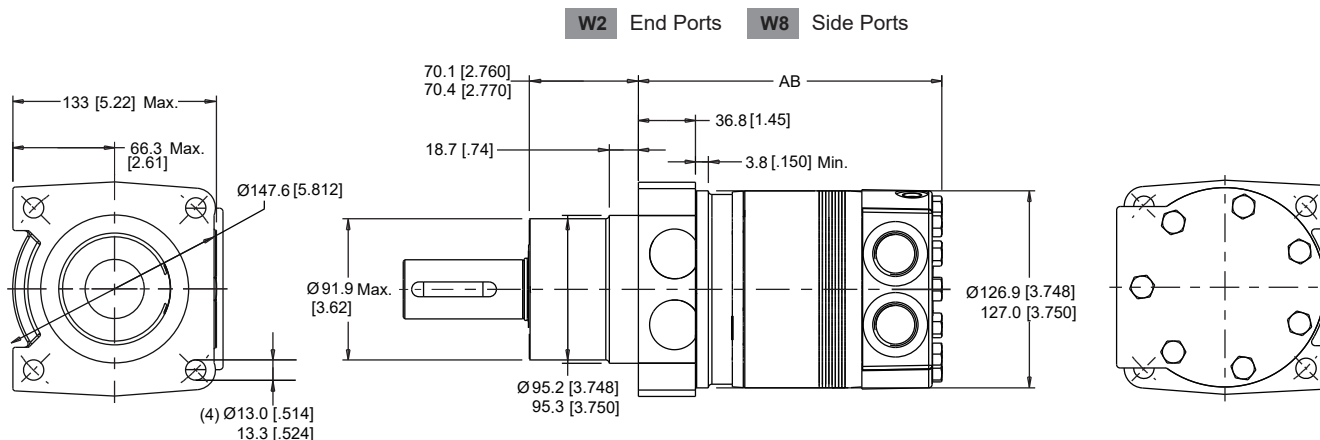

- ▶ Porting options listed on pages 35-36.
- ▶ Dimensions shown are without paint. Paint thickness can be up to 0.13 [0.005].

TECHNICAL INFORMATION

ALLOWABLE SHAFT LOAD / BEARING CURVE

The bearing curve represents allowable bearing loads based on ISO 281 bearing capacity for an L_{10} life of 2,000 hours at 100 RPM. Radial loads for speeds other than 100 RPM may be calculated using the multiplication factor table on page 8.

W2 & W8 WHEEL MOUNTS

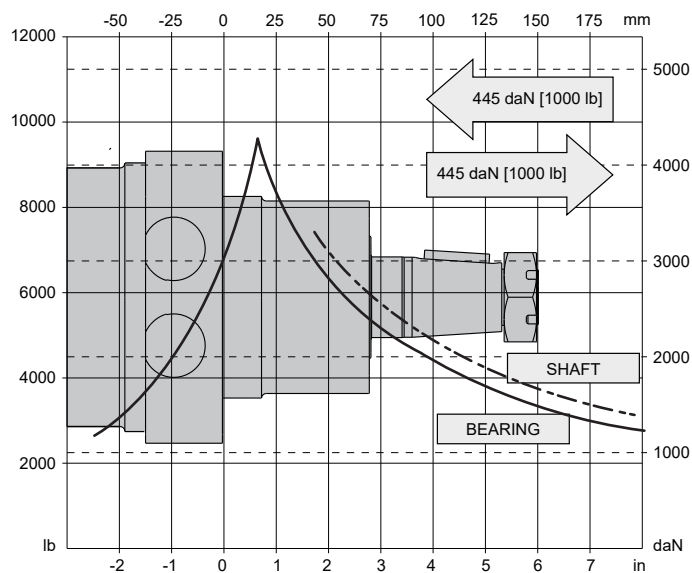

LENGTH & WEIGHT CHART

Dimension AB is the overall motor length from the rear of the motor to the mounting surface.

AB	Endcovers on pg. 35 mm [in]	Endcovers on pg. 36 mm [in]	Weight kg [lb]
300	173 [6.80]	175 [6.89]	19.8 [43.6]
375	179 [7.05]	181 [7.14]	20.4 [45.0]
470	187 [7.35]	189 [7.44]	21.0 [46.3]
540	195 [7.67]	197 [7.75]	21.5 [47.4]
750	211 [8.30]	213 [8.39]	23.0 [50.5]
930	226 [8.91]	228 [8.99]	24.0 [53.0]
1K1	236 [9.30]	238 [9.39]	24.9 [54.9]
1K5	274 [10.8]	277 [10.89]	28.0 [61.5]
2K1	325 [12.8]	327 [12.89]	31.9 [70.3]

- ▶ All WT series motor weights can vary ± 1.4 kg [3 lb] depending on model configurations such as housing, shaft, endcover, options etc.

PORTING

END PORTED - OFFSET

1 Main Ports **A, B:** 7/8 - 14 UNF
Drain Port **C:** 7/16 - 20 UNF

A Main Ports **A, B:** 1/2 - 14 BSP.F
Drain Port **C:** 1/4 - 19 BSP.F

STANDARD

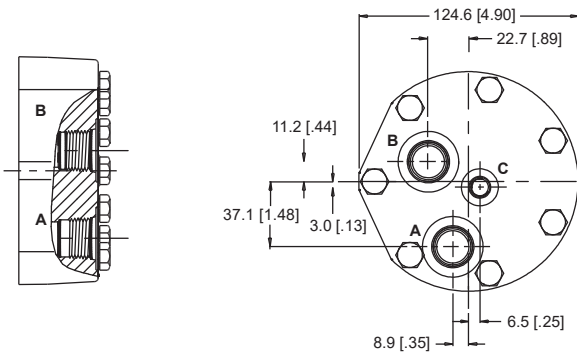

OPTIONAL

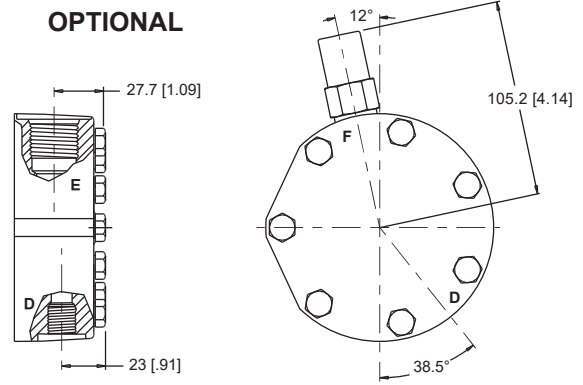

D: Internal Drain **E:** 10 Series/2-Way Valve Cavity 7/8-14 UNF **F:** Valve Cartridge Installed

SIDE PORTED - RADIAL

2 Main Ports **A, B:** G 3/4
Drain Port **C:** G 1/4

5 Main Ports **A, B:** 1 1/16 - 12 UN
Drain Port **C:** 7/16 - 20 UNF

STANDARD

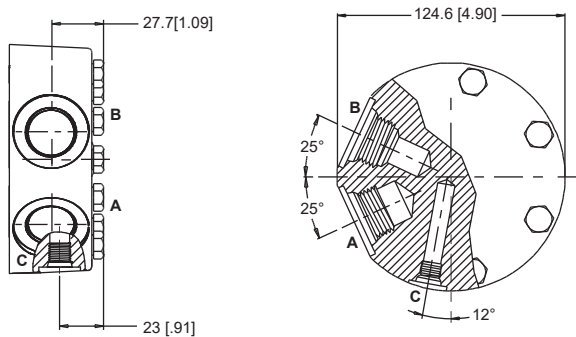

OPTIONAL

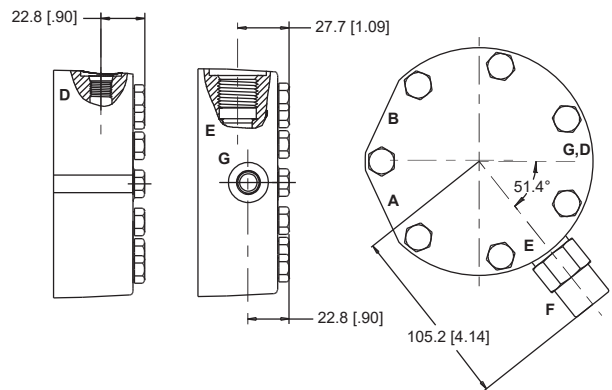

D: Internal Drain **E:** 10 Series/2-Way Valve Cavity 7/8-14 UNF **F:** Valve Cartridge Installed
G: Internal Drain Placement With Valve Cavity

► Dimensions shown are without paint. Paint thickness can be up to 0.13 [0.005].

WT (701 Series)

Heavy Duty Hydraulic Motor

PORTING

SIDE PORTED - MANIFOLD ALIGNED

3 Main Ports **A, B:** 11/16" Drilled
 Drain Port **C:** 7/16 - 20 UNF

STANDARD

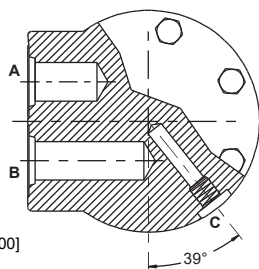
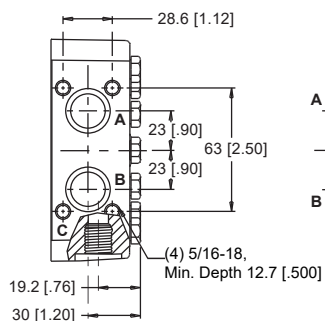

OPTIONAL

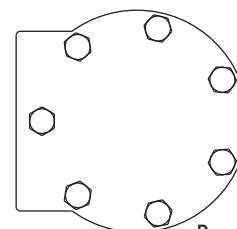
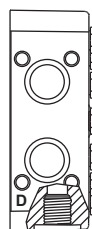

D: Internal Drain

SIDE PORTED - ALIGNED

6 Main Ports **A, B:** 1 1/16 - 12 UN
 Drain Port **C:** 7/16 - 20 UNF

7 Main Ports **A, B:** G 3/4
 Drain Port **C:** G 1/4

STANDARD

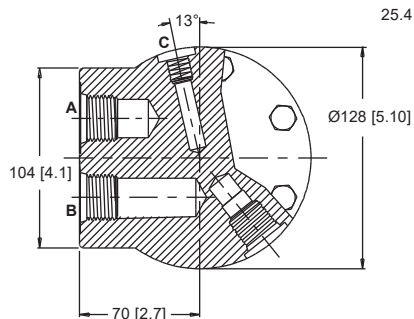
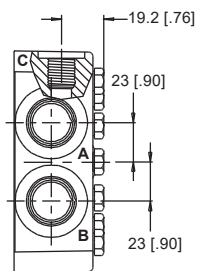

OPTIONAL

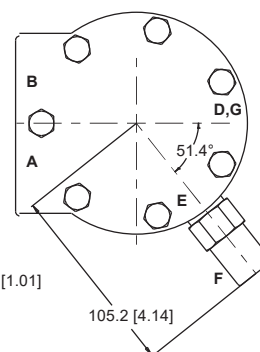
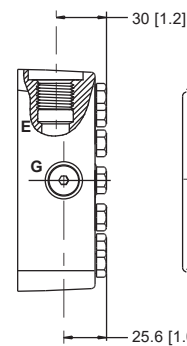

D: Internal Drain E: 10 Series/2-Way Valve Cavity 7/8-14 UNF
 G: Internal Drain Placement With Valve Cavity

F: Valve Cartridge Installed

► Dimensions shown are without paint. Paint thickness can be up to 0.13 [.005].

SHAFTS

23 14 Tooth Spline

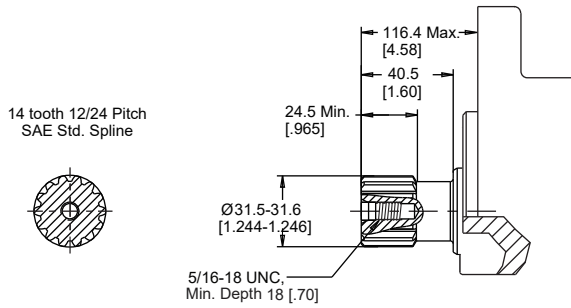

Max. Torque: 2070 Nm [18400 lb-in]

30 1-1/2" Straight

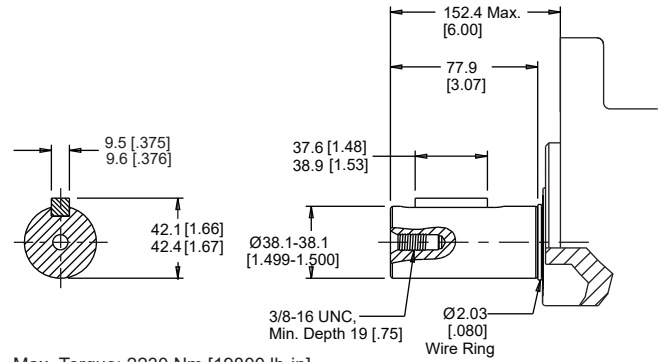

Max. Torque: 2230 Nm [19800 lb-in]

31 1-1/2" Tapered

► A slotted hex nut is standard on this shaft. Dimensional details & additional options are listed on page 13.

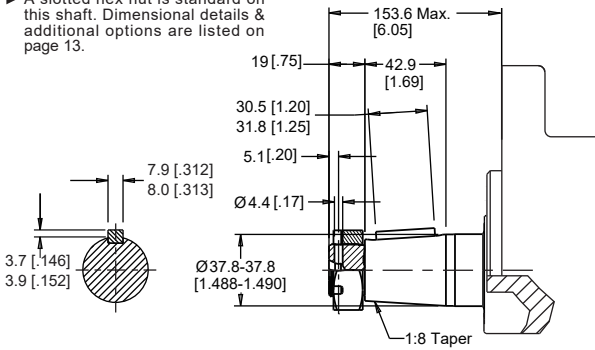

Max. Torque: 2250 Nm [19900 lb-in]

► Shaft lengths vary ± 0.8 mm [.030 in.]

37 1-1/2" 23 Tooth Spline

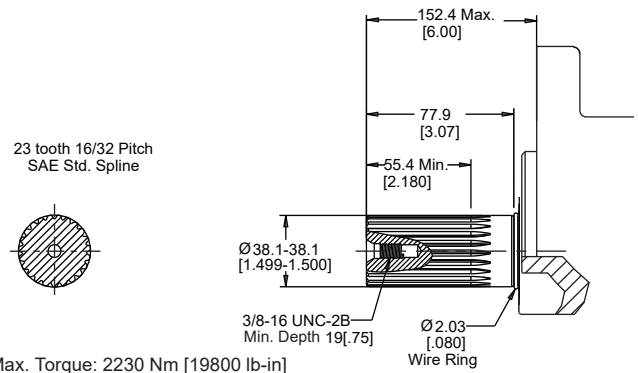

Max. Torque: 2230 Nm [19800 lb-in]

WT (701 Series)

Heavy Duty Hydraulic Motor

ORDERING INFORMATION



1. CHOOSE SERIES DESIGNATION

701 Standard Motor

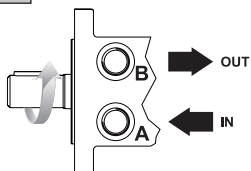

► The 701 series is bi-directional. Reversing the inlet hose will reverse shaft rotation.

2. SELECT A DISPLACEMENT OPTION

300	300 cm ³ /rev [18.3 in ³ /rev]	930	929 cm ³ /rev [56.7 in ³ /rev]
375	374 cm ³ /rev [22.8 in ³ /rev]	1K1	1047 cm ³ /rev [63.9 in ³ /rev]
470	464 cm ³ /rev [28.3 in ³ /rev]	1K5	1495 cm ³ /rev [91.2 in ³ /rev]
540	536 cm ³ /rev [32.7 in ³ /rev]	2K1	2093 cm ³ /rev [127.7 in ³ /rev]
750	747 cm ³ /rev [45.6 in ³ /rev]		

3a. SELECT MOUNT TYPE

▼ END MOUNTS

W2 4-Hole, Wheel Mount

▼ SIDE MOUNTS

W8 4-Hole, Wheel Mount

3b. SELECT PORT SIZE

▼ END PORT OPTIONS

1 7/8-14 UNF Offset

A 1/2" BSP

▼ SIDE PORT OPTIONS

2 G 3/4, Radial

3 11/16" Hole, Aligned Manifold

5 1 1/16-12 UN, Radial

6 1 1/16-12 UN, Aligned

7 G 3/4, Aligned

4. SELECT A SHAFT OPTION

23	14 Tooth Spline
30	1-1/2" Straight
31	1-1/2" Tapered
37	1-1/2" 23 Tooth Spline

► For options not listed in the table above, please contact us with your requirements.

5. SELECT A PAINT OPTION

A	Black
B	Black, Unpainted Mounting Surface
Z	No Paint

6. SELECT A VALVE CAVITY / CARTRIDGE OPTION

A	None	F	121 bar [1750 psi] Relief
B	Valve Cavity Only	G	138 bar [2000 psi] Relief
C	69 bar [1000 psi] Relief	J	173 bar [2500 psi] Relief
D	86 bar [1250 psi] Relief	L	207 bar [3000 psi] Relief
E	104 bar [1500 psi] Relief		

► Valve cavity is not available on port option 3.

7. SELECT AN ADD-ON OPTION

A	Standard
B	Lock Nut
C	Solid Hex Nut

8. SELECT A MISCELLANEOUS OPTION

AA	None
AB	Check Valve Integrated
AC	Freeturning Rotor
AD	Internal Drain & Freeturning Rotor

Impro *Fluidtek*

USA

400 E. Diehl Road, Suite 500
Naperville, IL 60563
USA

Email: sales.americas@improfluidtek.com

Luxembourg

10 Boulevard Royal, 2449
Luxembourg

Email: sales.emea@improfluidtek.com

China

No.18, Furong Road 5
Xishan Economy Development Zone
Wuxi, Jiangsu
China

Email: sales.apac@improfluidtek.com
